

LECTURE NOTE

ON

Design of Machine Elements

DIPLOMA 5TH SEM



DEPARTMENT OF MECHANICAL ENGINEERING

PREPARED BY:ER.AVAYA KUMAR BALIARSINGH

**GANESH INSTITUTE OF ENGINEERING AND TECHNOLOGY
(POLYTECHNIC)**

(Approved by AICTE)
ANDHARUA,BHUBANESWAR

OBJECTIVES

At the end of the course the students will be able to

1. Understanding the behaviours of material and their uses.
2. Understanding the design of various fastening elements and their industrial uses.
3. Understanding the different failures of design elements.
4. Understanding the change of design to accomplish the different field of applications.
5. Design shafts, keys, couplings required for power transmission.
6. Design closed coil helical spring

1.Introduction:

Introduction to Machine Design and Classify it.

Different mechanical engineering materials used in design with their uses and their mechanical and physical properties.

Define working stress, yield stress, ultimate stress & factor of safety and stress –strain curve for M.S & C.I.

Modes of Failure (By elastic deflection, general yielding & fracture)

State the factors governing the design of machine elements.

Describe design procedure.

2.Design of fastening elements:

2.1 Joints and their classification.

State types of welded joints .

State advantages of welded joints over other joints.

Design of welded joints for eccentric loads.

State types of riveted joints and types of rivets.

Describe failure of riveted joints.

Determine strength & efficiency of riveted joints.

Design riveted joints for pressure vessel.

Solve numerical on Welded Joint and Riveted Joints.

3.Design of shafts and Keys:

State function of shafts.

State materials for shafts.

Design solid & hollow shafts to transmit a given power at given rpm based on

a) Strength: (i) Shear stress, (ii) Combined bending tension;

b) Rigidity: (i) Angle of twist, (ii) Deflection, (iii) Modulus of rigidity

State standard size of shaft as per I.S.

State function of keys, types of keys & material of keys.

Describe failure of key, effect of key way.

Design rectangular sunk key considering its failure against shear & crushing.

Design rectangular sunk key by using empirical relation for given diameter of shaft.

State specification of parallel key, gib-head key, taper key as per I.S.

Solve numerical on Design of Shaft and keys.

4.Design of Coupling:

Design of Shaft Coupling

Requirements of a good shaft coupling

Types of Coupling.

Design of Sleeve or Muff-Coupling.

Design of Clamp or Compression Coupling.

Solve simple numerical on above.

5.Design a closed coil helical spring:

Materials used for helical spring.

Standard size spring wire. (SWG).

Terms used in compression spring.

Stress in helical spring of a circular wire.

Deflection of helical spring of circular wire.

Surge in spring.

Solve numerical on design of closed coil helical compression spring.

Chapter-1

INTRODUCTION TO DESIGN

INTRODUCTION:

The subject Machine Design is the creation of new and better machines and improving the existing ones. A new or better machine is one which is more economical in the overall cost of production and operation. The process of design is a long and time consuming one. From the study of existing ideas, a new idea has to be conceived.

The idea is then studied keeping in mind its commercial success and given shape and form in the form of drawings. In the preparation of these drawings, care must be taken of the availability of resources in money, in men and in materials required for the successful completion of the new idea into an actual reality. In designing a machine component, it is necessary to have a good knowledge of many subjects such as Mathematics, Engineering Mechanics, Strength of Materials, Theory of Machines, Workshop Processes and Engineering Drawing.

Classifications of Machine Design:

The machine design may be classified as follows:

1. Adaptive design: In most cases, the designer's work is concerned with adaptation of existing designs. This type of design needs no special knowledge or skill and can be attempted by designers of ordinary technical training. The designer only makes minor alternation or modification in the existing designs of the product.

2. Development design: This type of design needs considerable scientific training and design ability in order to modify the existing designs into a new idea by adopting a new material or different method of manufacture. In this case, though the designer starts from the existing design, but the final product may differ quite markedly from the original product.

3. New design: This type of design needs lot of research, technical ability and creative thinking. Only those designers who have personal qualities of a sufficiently high order can take up the work of a new design.

The designs, depending upon the methods used, may be classified as follows:

(a) Rational design: This type of design depends upon mathematical formulae of principle of mechanics. (b)

Empirical design: This type of design depends upon empirical formulae based on the practice and past experience.

(c) Industrial design: This type of design depends upon the production aspects to manufacture any machine component in the industry.

(d) Optimum design: It is the best design for the given objective function under the specified constraints. It may be achieved by minimising the undesirable effects.

(e) System design: It is the design of any complex mechanical system like a motor car.

(f) Element design: It is the design of any element of the mechanical system like piston, crankshaft, connecting rod, etc.

(g) Computer aided design: This type of design depends upon the use of computer systems to assist in the creation, modification, analysis and optimisation of a design.

Factors governing the design of machine elements:

Factors to be considered for selection of material for design of machine elements

- a) Availability: Material should be available easily in the market.
- b) Cost: the material should be available at cheaper rate.
- c) Manufacturing Consideration: the manufacturing play a vital role in selection of material and the material should suitable for required manufacturing process.
- d) Physical properties: like color, density etc.
- e) Mechanical properties: such as strength, ductility, Malleability etc.
- f) Corrosion resistance: it should be corrosion resistant.

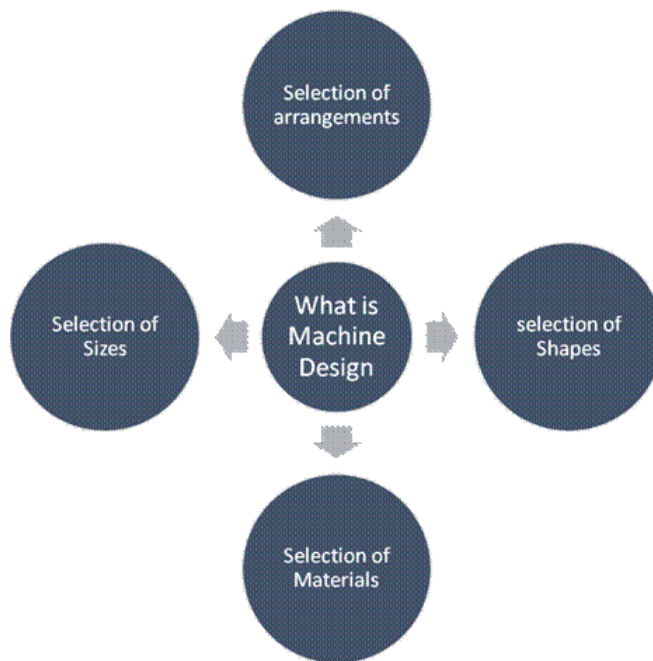

General Procedure in Machine Design:

In designing a machine component, there is no rigid rule. The problem may be attempted in several ways. However, the general procedure to solve a design problem is as follows:

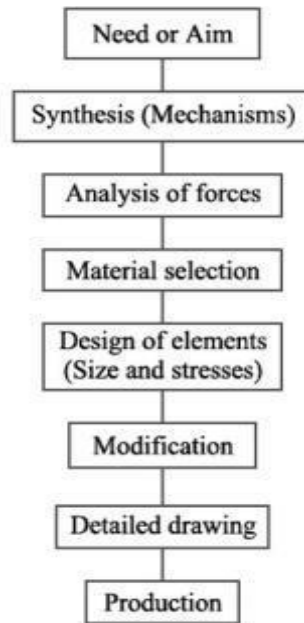

Fig. General Machine Design Procedure

1. Recognition of need: First of all, make a complete statement of the problem, indicating the need, aim or purpose for which the machine is to be designed.
2. Synthesis (Mechanisms): Select the will give the desired motion.
3. Analysis of forces: Find the forces acting on each member of the machine and the energy transmitted by each member.
4. Material selection: Select the material best suited for each member of the machine.
5. Design of elements (Size and Stresses): considering the force acting on the member and the permissible stresses for the material used. It should be kept in mind that each member should not deflect or deform than the permissible limit.
6. Modification: Modify the size of the member to agree with the past experience and judgment to facilitate manufacture. The modification may also be necessary by consideration of manufacturing to reduce overall cost.
7. Detailed drawing: Draw the detailed drawing of each component and the assembly of the machine with complete specification for the manufacturing processes suggested.
8. Production. The component, as per the drawing, is manufactured in the workshop. The flow chart for the general procedure in machine design is shown in Fig.

Engineering Materials:

The engineering materials are mainly classified as:

1. Metals and their alloys, such as iron, steel, copper, aluminum, etc.

2. Non-metals, such as glass, rubber, plastic, etc.

The metals may be further classified as:

1. Ferrous metals.

The Ferrous metals are those which have the iron as their main constituent, such as cast iron, wrought iron and steel.

2. Non-ferrous metals.

The Non-ferrous metals are those which have a metal other than iron as their main constituent, such as copper, aluminum, brass, tin, zinc, etc.

The selection of a proper material, for engineering purposes, is one of the most difficult problems for the designer. The best material is one which serves the desired objective at the minimum cost.

The following factors should be considered while selecting the material:

- Availability of the materials.
- Suitability of the materials for the working conditions in service.
- The cost of the materials.

Mechanical Properties of Metals:

The mechanical properties of the metals are those which are associated with the ability of the material to resist mechanical forces and load. These mechanical properties of the metal include; Strength, stiffness, elasticity, plasticity, ductility, brittleness, malleability, toughness, resilience, creep and hardness.

1. Strength: It is the ability of a material to resist the externally applied forces without breaking or yielding. The internal resistance offered by a part to an externally applied force is called stress.

2. Stiffness: It is the ability of a material to resist deformation under stress. The modulus of elasticity is the measure of stiffness.

3. Elasticity: It is the property of a material to regain its original shape after deformation when the external forces are removed.

4. Plasticity: It is property of a material which retains the deformation produced under load permanently.

5. Ductility: It is the property of a material enabling it to be drawn into wire with the application of a tensile force. A ductile material must be both strong and plastic. The ductility is usually measured by the terms, percentage elongation and percentage reduction in area. The ductile material commonly used in engineering practice are mild steel, copper, aluminum, nickel, zinc, tin and lead.

6. Brittleness: It is the property of a material opposite to ductility. It is the property of breaking of a material with little permanent distortion. Cast iron is a brittle material.

7. Malleability: It is a special case of ductility which permits materials to be rolled or hammered into thin sheets. The malleable materials commonly used in engineering practice are lead, soft steel, wrought iron, copper and aluminum.

8. Toughness: It is the property of a material to resist fracture due to high impact loads like hammer blows. The toughness of the material decreases when it is heated.

9. Resilience: It is the property of a material to absorb energy and to resist shock and impact loads. This property is essential for spring materials.

10. Creep: When a part is subjected to a constant stress at high temperature for a long period of time, it will undergo a slow and permanent deformation called creep. This property is considered in designing internal combustion engines, boilers and turbines.

11. Fatigue: When a material is subjected to repeated stresses, it fails at stresses below the yield point stresses. Such type of failure of a material is known as fatigue. This property is considered in designing shafts, connecting rods, springs, gears, etc.

12. Hardness: It is the property of the metals; it adopts many different properties such as resistance to wear, scratching, deformation and machinability etc. The hardness of a metal may be determined by the following tests:

- a) Brinell hardness test.
- b) Rockwell hardness test.
- c) Vickers hardness test.

Working Stress:

When designing machine parts, it is desirable to keep the stress lower than the maximum or ultimate stress at which failure of the material takes place. This stress is known as the working stress.

Factor of Safety:

It is defined, in general, as the ratio of the maximum stress to the working stress.

Mathematically, **Factor of safety = Maximum stress / Working or design stress**

- In case of ductile materials; e.g. mild steel, where the yield point is clearly defined, the factor of safety is based upon the yield point stress.

In such cases;

Factor of safety = Yield point stress / Working or design stress

- In case of brittle materials e.g. cast iron, the yield point is not well defined as for ductile materials. Therefore, the factor of safety for brittle materials is based on ultimate stress.

In such cases:

Factor of safety = Ultimate stress / Working or design stress

Stress Strain Curve for Mild Steel:

When a ductile material like mild steel is subjected to tensile force, it undergoes different stages before failure. Stress strain curve is the graphical representation of this stages. Different material may have different curve. Usually ductile materials follow similar pattern. so is for brittle materials. Here is the explanation of stress strain curve for mild steel which is ductile material.

Here is the list of different stages when ductile material subjected to force till its failure.

- Proportional limit (point A)
- Elastic limit (point B)
- Yield point (upper yield point C and lower yield point D)
- Ultimate stress point (point E)
- Breaking point (point F)

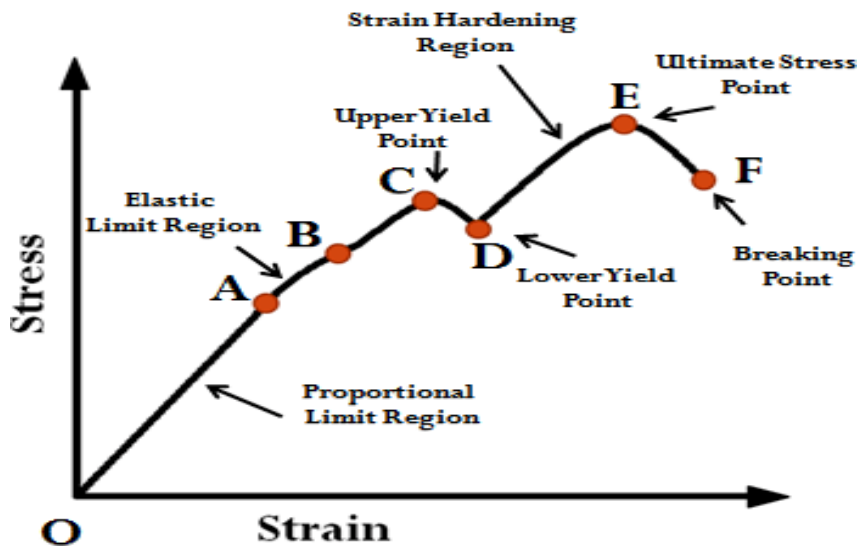

Fig. Stress-strain curve for mild steel

Proportional limit:

As shown in stress strain curve for mild steel, up to the point A, stress and strain follow a relationship. This is known as Hook's law. Up to the limit of proportionality, stress directly followed the strain. This means ratio of stress and strain remains constant

Elastic limit:

Up to this limit (point B), is material will regain its original shape is unloaded. Point B is known as elastic point.

Yield limit:

When material is loaded beyond its elastic limit, it will not regain its original shape. There will be always some deformation.

Ultimate stress:

This is the maximum stress a material can bear. Value of stress corresponds to peak point on stress strain curve for mild steel is the ultimate stress. It is denoted by point E in diagram.

Breaking stress:

Point on the stress strain curve where material fails, is known as breaking point. Stress correspond to this point is known as breaking stress.

Stress Strain Curve for cast iron:

Materials which show very small elongation before they fracture are called brittle materials. The shape of curve for a high carbon steel is shown in Fig.(b) and is typical of many brittle materials such as G.I, concrete and high strength light alloys. For most brittle materials the permanent elongation (i.e., increase in length) is less than 10%.

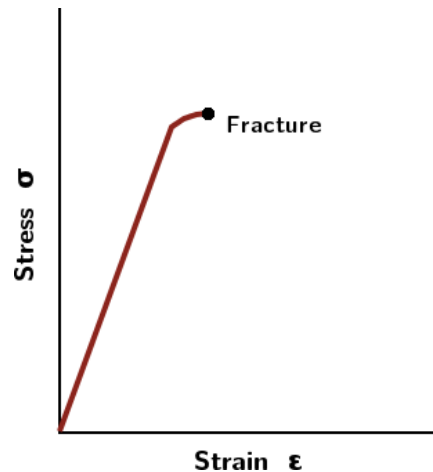

Fig. stress-strain curve for cast iron.

The ultimate strength is coincident with the fracture point. In this case, no necking occurs.

Modes of failure:

A mechanical component may fail i.e. it may be unable to perform its function satisfactorily, as a result of any one of the following three modes of failure:

1. Failure by elastic deflection.
2. Failure by Yielding
3. failure by Fracture

1. Failure by elastic deflection

- In applications like transmission shaft supporting the gears, the maximum force acting on the shaft, without effecting its performance is limited by the permissible elastic deflection. Sometimes the elastic deflection results in unstable conditions, such as buckling of columns or vibrations. The design of mechanical component, in all these cases, is based on the permissible lateral or torisional deflection. The stresses induced in the component are not significant and properties of the material are not of primary importance. The moduli of elasticity and rigidity are the important properties and dimension of component are determined by the load deflection equation.
- In short, in a components like : columns, beams, shafts etc.,the torsional deflection in an elastic region is termed as failure of the component

2. Failure by Yielding

- For ductile material deformation occurs after the yield point, resulting in permanent deformation of the machine element which ultimately breaks at breaking point. Hence for ductile materials, failure is usually considered to have occurred when yielding i.e. plastic deformation reach a limit, when engineering usefulness of the part is destroyed, even through there is no rupture or fracture of machine part. Thus, the yield point is criterion of failure of ductile materials subjected to static loading.
- In short, when a mechanical component, made of ductile material, undergoes yielding or plastic deformation, its functional utility comes to an end and it is termed as failure of the component. Such failure is known as **elastic failure**.

3. Failure by fracture

- In case of brittle materials the yield point and ultimate strain is very nearly equal to unity. So brittle materials are considered to have failed by fracture with little or no permanent deformation.
- Sudden separation or a breakage of a material along the cross-section normal to the direction of stress is known as fracture. Fracture is a sudden failure without plastic deformation. The failure of components made of brittle material is due to fracture.

Chapter-2

DESIGN OF FASTENING ELEMENTS

Fasteners: It is a Mechanical Joints which is used to become a fixed / attaches to something or holds something in place.

The Fastenings may be classified into the following two groups:

1. The Permanent Fastenings are those fastenings which cannot be disassembled without destroying the connecting components. Examples: Welded joint, Rivet joint.
2. The Temporary or Detachable Fastenings are those fastenings which can be disassembled without destroying the connecting components.

Examples: 1. Thread Joints

- a. Bolted Joints
 - b. Screws Joints
2. Keys
 3. Coupling
 4. Pins Joints
 - a. Cotters Joints
 - b. Knuckle Joints
 5. Pipe Joints

Welded joint:

Welding can be defined as a process of joining metallic parts by heating to a suitable temperature with or without the application of pressure.

Welding is an economical and efficient method for obtaining a permanent joint of metallic parts.

Two distinct application of welding

1. Can be used as a substitute for a riveted joint
2. Welded structure as an alternative method for casting or forging.

Welding advantages over riveting:

Welded joint	Rivet joint
Due to no additional parts except melting of filler rods, welded joints are lighter in weight. Welded steel structures are lighter than the corresponding iron castings by 50% and steel castings by 30%	Requires cover plates, gusset plates, straps, clip angles and large number of rivets which increases the weight
Cost is lesser due to no additional components used	Cost is higher due to usage of additional components listed above
Alterations and additions of the design of welded assemblies can be easily and economically modified	Alterations and additions of design of riveted assemblies are not easier and economically changed
Production time is less	Production time is higher
Welding does not create stress concentration due to lack of drilling holes.	Holes are drilled to accommodate the rivets. The holes reduces the cross-sectional area of the members and result in stress concentration.
Strength of weld is higher. Strength of weld is more than the strength of the plates that are joined together.	Strength of rivets are not high as that of weld joints.
Machine components of certain shapes such as circular steel pipe can easily be constructed by welding.	Machine components of certain shapes such as circular steel pipe , find difficulty in riveting

Disadvantages of welding:

1. The capacity of weld structures to damp vibrations is poor
2. Welding results in a thermal distortion of the parts, there by inducing residual stresses.
3. In many cases, stress-relieving heat treatment is required to relieve residual Stresses.
4. The quality and strength of the welded joint depend upon the skill of the welder. It is difficult to control the quality when a number of welders are involved.
5. The inspection of the welded joint is more specialized and costly compared with the inspection of riveted or cast structures

Eccentrically Loaded Welded Joints

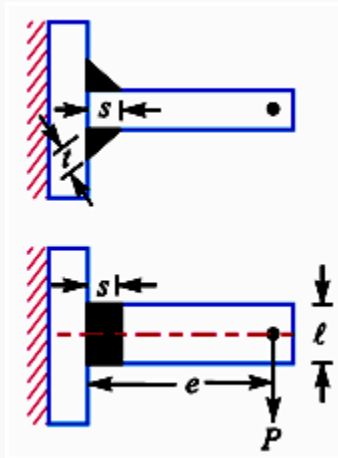

Figure. Bending Stress due to Eccentricity

In many cases the welded joints are eccentrically loaded. Different stresses may get induced depending upon the type of joint and loading. If the stresses are of same nature, those may be vectorially added but for those of different nature, resultant maximum tensile and shear stresses may be calculated. Depending upon the type of joint, eccentricity may lead to bending stress or torsional shear stress in the joint in addition to the direct shear stress induced by applied load.

Eccentricity leading to Bending Stress:

Consider a T-joint subjected to loading as shown in figure.

Let s and l be the size and length of the weld and t be the throat thickness.

$$\text{Throat area} = A = 2. t. l$$

This applied load may be considered as a load P directly acting on the joint through the CG and a bending moment of magnitude $P.e$ acting on the joint. 1st one will lead to direct shear stress and the 2nd will lead to a bending stress.

Direct Shear Stress,

$$\tau = \frac{P}{A} = \frac{P}{2tl}$$

and Bending Stress,

$$\sigma_b = \frac{My}{I}$$

where y = distance of the point on the weld from the neutral axis

I = Moment of inertia of the weld section

Maximum tensile and shear stress may be calculated as:

$$\sigma_{t_{max.}} = \left(\frac{\sigma_b}{2}\right)^2 + \sqrt{\left(\frac{\sigma_b}{2}\right)^2 + (\tau)^2}$$

and

$$\tau_{max.} = \sqrt{\left(\frac{\sigma_b}{2}\right)^2 + (\tau)^2}$$

Eccentricity Leading to Torsional Shear Stress:

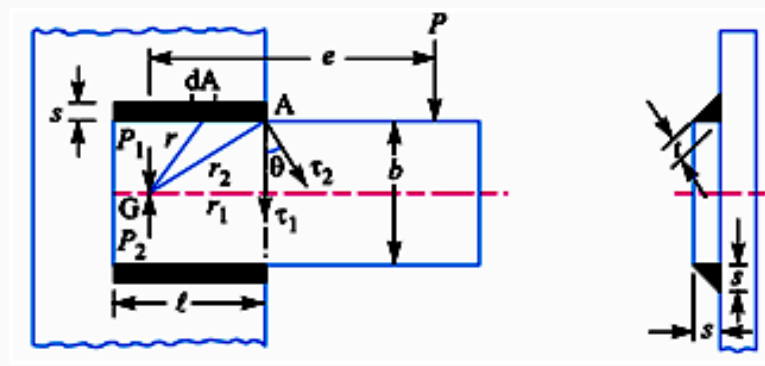

Figure. Shear Stress due to Eccentricity

Let us consider a double parallel fillet weld subjected to an eccentric load P acting at a distance e from the CG of the welds as shown in Figure.

Eccentric force P may be considered as a force P acting on the CG of the joint and a torque equivalent to Pe acting on the joint. The force P through the CG leads to direct shear stress, called primary shear stress and is assumed to be uniformly distributed over the throat area of all welds. The torque Pe causes torsional shear stress called secondary shear stress.

Primary Shear Stress,

$$\tau_1 = \frac{P}{A} = \frac{P}{2tl}$$

And, Secondary Shear Stress,

$$\tau_2 = \frac{Mr}{J}$$

where r = distance of the point on the weld from the CG

J = Polar moment of inertia of the weld section

r is calculated from the geometry for the farthest point of the weld from the CG.

Q.1. A rectangular steel plate is welded as a cantilever to a vertical column and supports a single concentrated load of 60 kN as shown in figure below. Determine the weld size if the allowable shear stress in the weld material is 140 MPa.

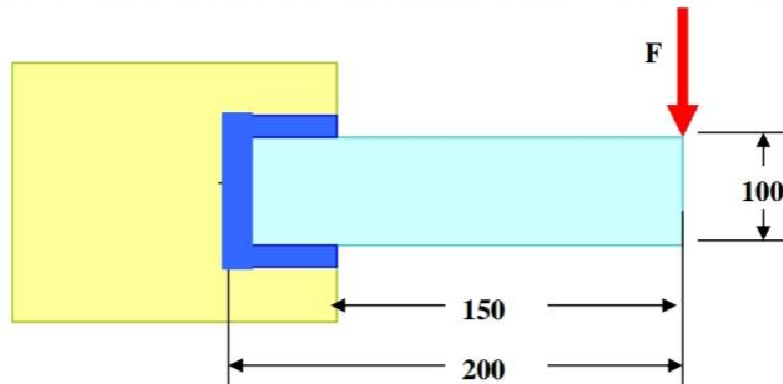

Ans. The weld is subjected to two shear stresses

- (1) Direct shear of magnitude $60,000/\text{Area of the weld}$. The area of the throat section is easily found out to be $200 t$ where $t=0.707 h$. Thus direct shear stress is $424/h$ MPa.
- (2) The indirect shear stress as a point r distance away from the centroid of the throat section has magnitude

$$\tau = \frac{FLr}{J},$$

where J is the polar moment of area of the throat section and L is the eccentricity of the load. From the geometry of the throat section it may be calculated that the distance of centroid from left end =

$$x = \frac{l^2}{2l+b} = 12.5 \text{ mm (see figure below) and the polar moment about G}$$

is

$$J = \frac{h}{\sqrt{2}} \left[\frac{(b+2l)^3}{12} - \frac{l^2(b+l)^2}{b+2l} \right] = 272530 h \text{ mm}^4.$$

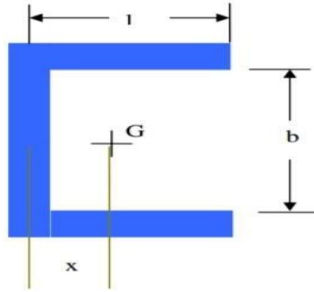

Thus the indirect shear stress has magnitude $\frac{41.28}{h} r$ MPa. The maximum resultant shear stress depends on both the magnitude and direction of the indirect shear stress. It should be clear that the maximum shear stress appears at the extreme corner of the weld section which is at a distance $\sqrt{\left(\frac{b}{2}\right)^2 + (l-x)^2} = 62.5$ mm away from the centroid. Noticing that the included angle between the two shear forces as $\cos^{-1}\left(\frac{l-x}{r_{\max}}\right) \approx 53.13^\circ$, the maximum value of the resultant shear stress is found out to be $f_{\max} = \frac{2854.62}{h}$ MPa. Since this value should not exceed 140 MPa the minimum weld size must be $h = 20.39$ mm.

A rectangular cross-section bar is welded to a support by means of fillet welds as shown in figure. Determine the size of the welds, if the permissible shear stress in the weld is limited to 75 MPa.

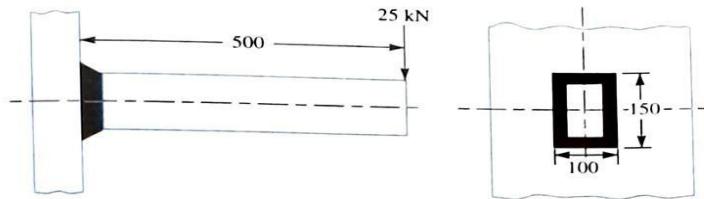

All dimensions in mm

Fig. 10.26

Solution. Given : $P = 25$ kN = 25×10^3 N ; $\tau_{\max} = 75$ MPa = 75 N/mm² ; $l = 100$ mm ; $b = 150$ mm ; $e = 500$ mm

Let s = Size of the weld, and
 t = Throat thickness.

The joint, as shown in Fig. 10.26, is subjected to direct shear stress and the bending stress. We know that the throat area for a rectangular fillet weld,

$$A = t(2b + 2l) = 0.707s(2b + 2l) \\ = 0.707s(2 \times 150 + 2 \times 100) = 353.5s \text{ mm}^2 \quad \dots (\because t = 0.707s)$$

$$\therefore \text{Direct shear stress, } \tau = \frac{P}{A} = \frac{25 \times 10^3}{353.5s} = \frac{70.72}{s} \text{ N/mm}^2$$

We know that bending moment,

$$M = P \times e = 25 \times 10^3 \times 500 = 12.5 \times 10^6 \text{ N-mm}$$

From Table 10.7, we find that for a rectangular section, section modulus,

$$Z = t \left(bl + \frac{b^2}{3} \right) = 0.707s \left[150 \times 100 + \frac{(150)^2}{3} \right] = 15907.5s \text{ mm}^3$$

$$\therefore \text{Bending stress, } \sigma_b = \frac{M}{Z} = \frac{12.5 \times 10^6}{15907.5s} = \frac{785.8}{s} \text{ N/mm}^2$$

We know that maximum shear stress (τ_{\max}),

$$75 = \frac{1}{2} \sqrt{(\sigma_b)^2 + 4\tau^2} = \frac{1}{2} \sqrt{\left(\frac{785.8}{s}\right)^2 + 4\left(\frac{70.72}{s}\right)^2} = \frac{399.2}{s}$$

$$\therefore s = 399.2 / 75 = 5.32 \text{ mm Ans.}$$

Riveted joint:

The rivets are used to make permanent fastening between the two or more plates such as in structural work, ship building, bridges, tanks and boiler shells. The riveted joints are widely used for joining light metals. A rivet is a short cylindrical bar with a head integral to it. The cylindrical portion of the rivet is called shank or body and lower portion of shank is known as tail.

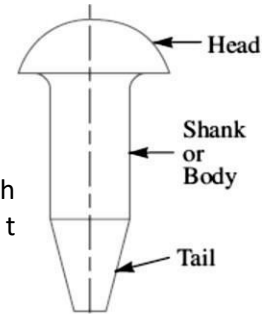

Methods of Riveting

The function of rivets in a joint is to make a connection that has strength and tightness. It is necessary to prevent failure of the joint. The tightness is necessary in order to contribute to prevent leakage as in a boiler or in a ship hull (The frame or body of ship).

When two plates are to be fastened together by a rivet as shown below, the holes in the plates are punched and reamed or drilled. Punching is the cheapest method and is used for relatively thin plates and in structural work. Since punching injures the material around the hole, therefore drilling is used in most pressure-vessel work.

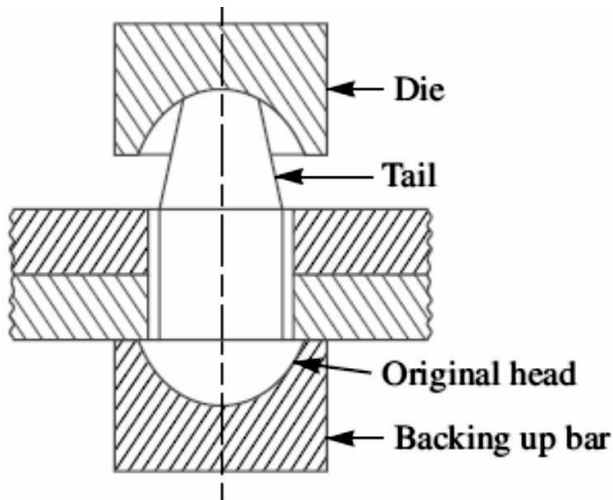

(a) Initial position.

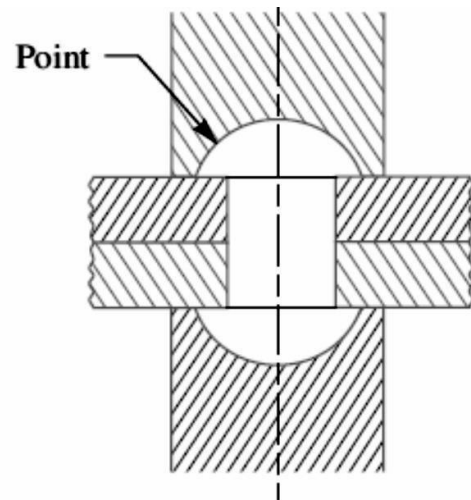

(b) Final position.

Material of Rivets:

The material of the rivets must be tough and ductile. They are usually made of steel (low carbon steel or nickel steel), brass, aluminum or copper, but when strength and a fluid tight joint is the main consideration, then the steel rivets are used. The rivets for general purposes shall be manufactured from steel conforming to the following Indian Standards:

1. IS: 1148–1982 (Reaffirmed 1992) – Specification for hot rolled rivet bars (up to 40 mm diameter) for structural purposes; or
2. IS: 1149–1982 (Reaffirmed 1992) – Specification for high tensile steel rivet bars for structural purposes.
3. The rivets for boiler work shall be manufactured from material conforming to IS: 1990 – 1973 (Reaffirmed 1992) – Specification for steel rivets and stay bars for boilers.

Manufacture of Rivets

The rivets may be made either by cold heading or by hot forging.

- If rivets are made by the cold heading process, they are heat treated so that the stresses set up in the cold heading process are eliminated.
- If they are made by hot forging process, care shall be taken to see that the finished rivets cool gradually.

Note: when the diameter of rivet is 12 mm or less generally cold riveting is adopted.

Types of Rivets:

1. Button Head
2. Counter sunk Head
3. Oval counter Head
4. Pan Head
5. Conical Head

Types of Riveted Joints

1. According to purpose
2. According to position of plates connected
3. According to arrangement of rivets

1. According to purpose:

- a) Strong Joints: In these Joints strength is the only criterion.
Eg: Beams, Trusses and Machine Joints.
- b) Tight joints: These joints provide strength as well as are leak proof against low pressure.
Eg: Reservoir, Containers and tanks.
- c) Strong-Tight Joints: These are the joints applied in boilers and pressure vessels and ensure both strength and leak proofness.

2. According to position of plates:

- **Lap Joint:** A lap joint is that in which one plate overlaps the other and the two plates are then riveted together.
- **Butt Joint:** A butt joint is that in which the main plates are touching each other and a cover plate (i.e. Strap) is placed either on one side or on both sides of the main plates. The cover plate is then riveted together with the main plates. Butt joints are of the following two types:
 - a. In a single strap butt joint, the edges of the main plates butt against each other and only one cover plate is placed on one side of the main plates and then riveted together.
 - b. In a double strap butt joint, the edges of the main plates butt against each other and two cover plates are placed on both sides of the main plates and then riveted together.

3. According to arrangement of rivets:

- a. A **single riveted joint** is that in which there is a single row of rivets in a lap joint as shown in Fig. and there is a single row of rivets on each side in a butt joint.
- b. A **double riveted joint** is that in which there are two rows of rivets in a lap joint as shown in Fig. and there are two rows of rivets on each side in a butt joint.

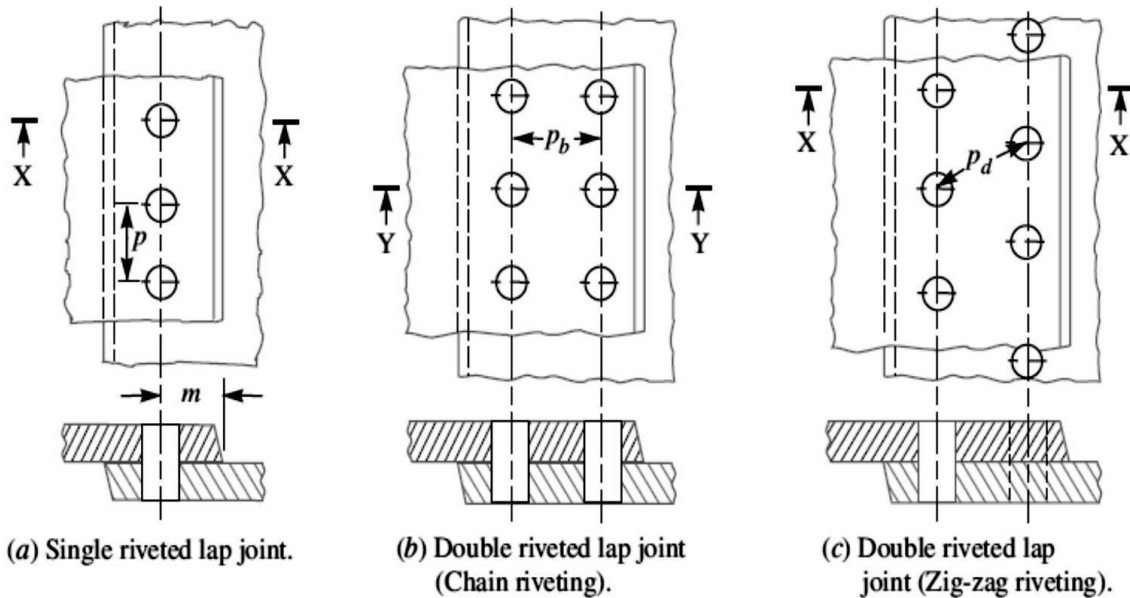

Important terms of Riveted joints:

1. **Pitch (p):** The Distance between two adjacent rivet holes in a row.
2. **Back pitch (P_b):** The Distance between two adjacent rows of rivets.
3. **Diagonal pitch(P_d):** The smallest distance between centers of two rivet holes in adjacent rows of ZIG-Zag riveted joints.
4. **Margin (m):** It is the distance between center of a rivet hole and nearest edge of the plate.

Modes of Failures of a Riveted Joint

1. **Tearing of the plate at the section weakened by holes:** Due to the tensile stresses in the main plates, the main plate or cover plates may tear off across a row of rivets as shown in Fig. In such cases, we consider only one pitch length of the plate, since every rivet is responsible for that much length of the plate only.

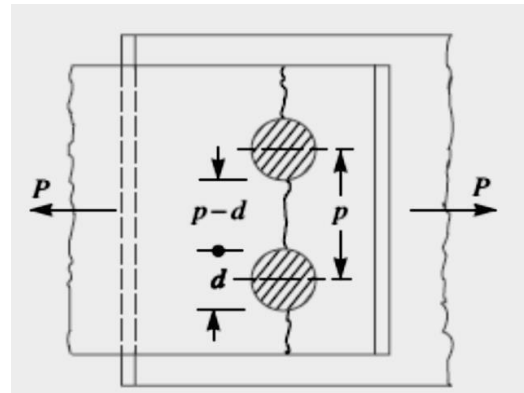

The resistance offered by the plate against tearing is known as tearing resistance or tearing strength or tearing value of the plate.

Let, p = Pitch of the rivets,
 d = Diameter of the rivet hole,
 t = Thickness of the plate, and
 σ_t = Permissible tensile stress for the plate material.

We know that tearing area per pitch length,
 $A_t = (p - d) t$

Tearing resistance or pull required to tear off the plate per pitch length,

$$P_t = A_t \cdot \sigma_t = (p - d) t \cdot \sigma_t$$

When the tearing resistance (P_t) is greater than the applied load (P) per pitch length, then this type of failure will not occur.

2. Shearing of the rivets:

The plates which are connected by the rivets exert tensile stress on the rivets, and if the rivets are unable to resist the stress, they are sheared off as shown in Fig.

It may be noted that the rivets are in single shear in a lap joint and in a single cover butt joint, as shown in Fig.

But the rivets are in double shear in a double cover butt joint as shown in Fig. The resistance offered by rivet to be sheared off is known as shear resistance or shearing strength or shearing value of the rivet.

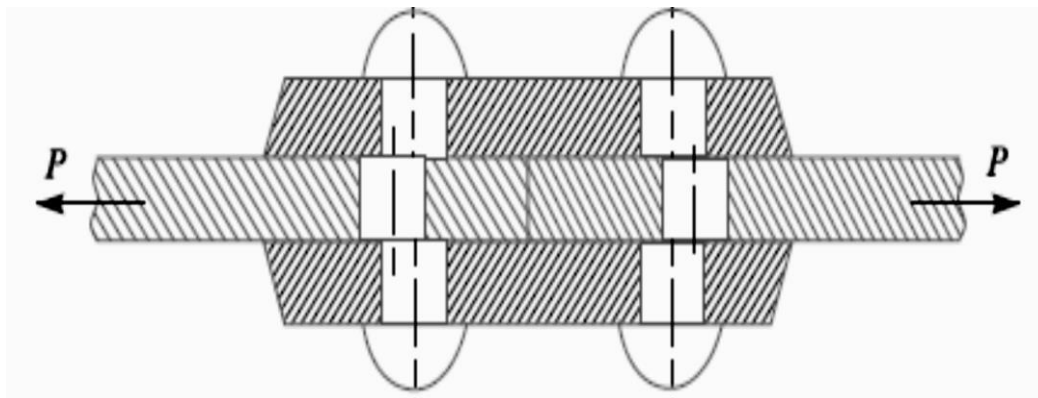
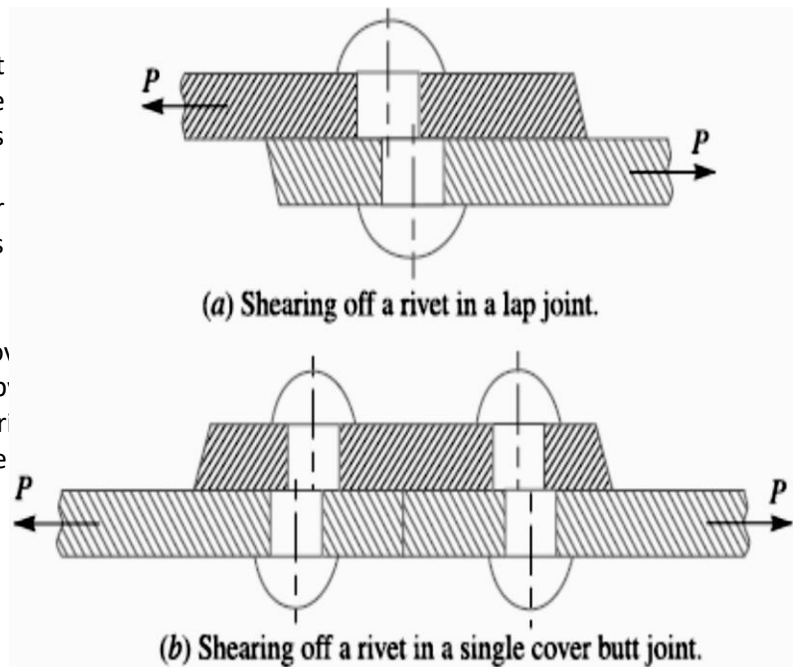

Let d = Diameter of the rivet hole,
 τ = Safe permissible shear stress for the rivet material, n
 $=$ Number of rivets per pitch length.

We know that shearing area,

$$A_s = (\pi/4) \times d^2 \quad \dots \text{ (In single shear)}$$

$$= 2 \times (\pi/4) \times d^2 \quad \dots \text{ (Theoretically, in double shear)}$$

Shearing resistance required to shear off the rivet per pitch length,

$$P_s = n \times (\pi/4) \times d^2 \times \tau \quad \dots(\text{In single shear})$$

$$= n \times 2 \times (\pi/4) \times d^2 \times \tau \quad \dots(\text{Theoretically, in double shear})$$

When the shearing resistance (P_s) is greater than the applied load (P) per pitch length, then this type of failure will occur.

- 3. Crushing of the plate or rivets:** Sometimes, the rivets do not actually shear off under the tensile stress, but are crushed as shown in Fig. Due to this, the rivet hole becomes of an oval shape and hence the joint becomes loose. The failure of rivets in such a manner is also known as bearing failure. The area which resists this action is the projected area of the hole or rivet on diametral plane.

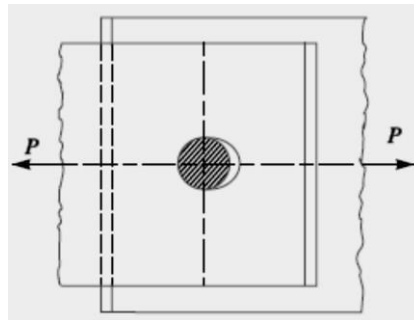

The resistance offered by a rivet to be crushed is known as crushing resistance or crushing strength or bearing value of the rivet.

Let d = Diameter of the rivet hole,

t = Thickness of the plate,

σ_c = Safe permissible crushing stress for the rivet or plate material,
and n = Number of rivets per pitch length under crushing.

We know that crushing area per rivet (i.e. projected area per rivet),

$$A_c = d \cdot t$$

\therefore Total crushing area = $n \cdot d \cdot t$

and crushing resistance or pull required to crush the rivet per pitch length,

$$P_c = n \cdot d \cdot t \cdot \sigma_c$$

When the crushing resistance (P_c) is greater than the applied load (P) per pitch length, then this type of failure will occur.

Note: The number of rivets under shear shall be equal to the number of rivets under crushing.

Unwin's Formula: As a Common Practice for plate thickness greater than 8 mm, the diameter of rivet hole is determined by: $d = 6 \sqrt{t}$ (t = thickness of plate)

Strength of a Riveted Joint:

The strength of a joint may be defined as the maximum force, which it can transmit, without causing it to fail.

We have seen that P_t , P_s and P_c are the pulls required to tear off the plate, shearing off the rivet and crushing off the rivet. A little consideration will show that if we go on increasing the pull on a riveted joint, it will fail when the least of these three pulls is reached, because a higher value of the other pulls will never reach since the joint has failed, either by tearing off the plate, shearing off the rivet or crushing off the rivet.

If the joint is continuous as in case of boilers, the strength is calculated per pitch length.

But if the joint is small, the strength is calculated for the whole length of the plate.

Efficiency of a Riveted Joint:

The efficiency of a riveted joint is defined as the ratio of the strength of riveted joint to the strength of the un-riveted or solid plate. We have already discussed that strength of the riveted joint

$$= \text{Least of } P_t, P_s \text{ and } P_c$$

Strength of the un-riveted or solid plate per pitch length,

$$P = p \cdot t \cdot \sigma_t$$

∴ Efficiency of the riveted joint,

$$\eta = \frac{\text{Least of } P_t, P_s \text{ and } P_c}{p \times t \times \sigma_t}$$

Where, σ_t = Permissible tensile stress of the plate material

p = Pitch of the rivets,

t = Thickness of the plate

Q.1: A double riveted lap joint is made between 15 mm thick plates. The rivet diameter and pitch are 25 mm and 75 mm respectively. If the ultimate stresses are 400 MPa in tension, 320 MPa in shear and 640 MPa in crushing, find the minimum force per pitch which will rupture the joint. If the above joint is subjected to a load such that the factor of safety is 4, find out the actual stresses developed in the plates and the rivets.

Solution. Given : $t = 15 \text{ mm}$; $d = 25 \text{ mm}$; $p = 75 \text{ mm}$; $\sigma_{tu} = 400 \text{ MPa} = 400 \text{ N/mm}^2$; $\tau_u = 320 \text{ MPa} = 320 \text{ N/mm}^2$; $\sigma_{cu} = 640 \text{ MPa} = 640 \text{ N/mm}^2$

Minimum force per pitch which will rupture the joint

Since the ultimate stresses are given, therefore we shall find the ultimate values of the resistances of the joint. We know that ultimate tearing resistance of the plate per pitch,

$$P_{tu} = (p - d)t \times \sigma_{tu} = (75 - 25)15 \times 400 = 300\,000 \text{ N}$$

Ultimate shearing resistance of the rivets per pitch,

$$P_{su} = n \times \frac{\pi}{4} \times d^2 \times \tau_u = 2 \times \frac{\pi}{4} (25)^2 320 = 314\,200 \text{ N} \quad \dots (\because n = 2)$$

and ultimate crushing resistance of the rivets per pitch,

$$P_{cu} = n \times d \times t \times \sigma_{cu} = 2 \times 25 \times 15 \times 640 = 480\,000 \text{ N}$$

From above we see that the minimum force per pitch which will rupture the joint is 300 000 N or 300 kN. **Ans.**

Actual stresses produced in the plates and rivets

Since the factor of safety is 4, therefore safe load per pitch length of the joint

$$= 300\,000 / 4 = 75\,000 \text{ N}$$

Let σ_{ta} , τ_a and σ_{ca} be the actual tearing, shearing and crushing stresses produced with a safe load of 75 000 N in tearing, shearing and crushing.

We know that actual tearing resistance of the plates (P_{ta}),

$$75\,000 = (p - d)t \times \sigma_{ta} = (75 - 25)15 \times \sigma_{ta} = 750 \sigma_{ta}$$

$$\therefore \sigma_{ta} = 75\,000 / 750 = 100 \text{ N/mm}^2 = 100 \text{ MPa} \quad \text{Ans.}$$

Actual shearing resistance of the rivets (P_{sa}),

$$75\,000 = n \times \frac{\pi}{4} \times d^2 \times \tau_a = 2 \times \frac{\pi}{4} (25)^2 \tau_a = 982 \tau_a$$

$$\therefore \tau_a = 75\,000 / 982 = 76.4 \text{ N/mm}^2 = 76.4 \text{ MPa} \quad \text{Ans.}$$

and actual crushing resistance of the rivets (P_{ca}),

$$75\,000 = n \times d \times t \times \sigma_{ca} = 2 \times 25 \times 15 \times \sigma_{ca} = 750 \sigma_{ca}$$

$$\therefore \sigma_{ca} = 75\,000 / 750 = 100 \text{ N/mm}^2 = 100 \text{ MPa} \quad \text{Ans.}$$

Q.2: Find the efficiency of the following riveted joints:

1. Single riveted lap joint of 6 mm plates with 20 mm diameter rivets having a pitch of 50 mm.
2. Double riveted lap joint of 6 mm plates with 20 mm diameter rivets having a pitch of 65 mm. Assume Permissible tensile stress in plate = 120 MPa Permissible shearing stress in rivets = 90 MPa Permissible crushing stress in rivets = 180 MPa.

Solution. Given : $t = 6 \text{ mm}$; $d = 20 \text{ mm}$; $\sigma_t = 120 \text{ MPa} = 120 \text{ N/mm}^2$; $\tau = 90 \text{ MPa} = 90 \text{ N/mm}^2$;
 $\sigma_c = 180 \text{ MPa} = 180 \text{ N/mm}^2$

1. *Efficiency of the first joint*

Pitch, $p = 50 \text{ mm}$... (Given)

First of all, let us find the tearing resistance of the plate, shearing and crushing resistances of the rivets.

(i) *Tearing resistance of the plate*

We know that the tearing resistance of the plate per pitch length,

$$P_t = (p - d) t \times \sigma_t = (50 - 20) 6 \times 120 = 21\,600 \text{ N}$$

(ii) *Shearing resistance of the rivet*

Since the joint is a single riveted lap joint, therefore the strength of one rivet in single shear is taken. We know that shearing resistance of one rivet,

$$P_s = \frac{\pi}{4} \times d^2 \times \tau = \frac{\pi}{4} (20)^2 90 = 28\,278 \text{ N}$$

(iii) *Crushing resistance of the rivet*

Since the joint is a single riveted, therefore strength of one rivet is taken. We know that crushing resistance of one rivet,

$$P_c = d \times t \times \sigma_c = 20 \times 6 \times 180 = 21\,600 \text{ N}$$

\therefore Strength of the joint

$$= \text{Least of } P_t, P_s \text{ and } P_c = 21\,600 \text{ N}$$

We know that strength of the unriveted or solid plate,

$$P = p \times t \times \sigma_t = 50 \times 6 \times 120 = 36\,000 \text{ N}$$

\therefore Efficiency of the joint,

$$\eta = \frac{\text{Least of } P_t, P_s \text{ and } P_c}{P} = \frac{21\,600}{36\,000} = 0.60 \text{ or } 60\% \text{ Ans.}$$

2. *Efficiency of the second joint*

Pitch, $p = 65 \text{ mm}$... (Given)

(i) *Tearing resistance of the plate,*

We know that the tearing resistance of the plate per pitch length,

$$P_t = (p - d) t \times \sigma_t = (65 - 20) 6 \times 120 = 32\,400 \text{ N}$$

(ii) *Shearing resistance of the rivets*

Since the joint is double riveted lap joint, therefore strength of two rivets in single shear is taken. We know that shearing resistance of the rivets,

$$P_s = n \times \frac{\pi}{4} \times d^2 \times \tau = 2 \times \frac{\pi}{4} (20)^2 90 = 56\,556 \text{ N}$$

(iii) *Crushing resistance of the rivet*

Since the joint is double riveted, therefore strength of two rivets is taken. We know that crushing resistance of rivets,

$$P_c = n \times d \times t \times \sigma_c = 2 \times 20 \times 6 \times 180 = 43\,200 \text{ N}$$

\therefore Strength of the joint

$$= \text{Least of } P_t, P_s \text{ and } P_c = 32\,400 \text{ N}$$

We know that the strength of the unriveted or solid plate,

$$P = p \times t \times \sigma_t = 65 \times 6 \times 120 = 46\,800 \text{ N}$$

∴ Efficiency of the joint,

$$\eta = \frac{\text{Least of } P_t, P_s \text{ and } P_c}{P} = \frac{32\,400}{46\,800} = 0.692 \text{ or } 69.2\% \quad \text{Ans.}$$

Q.3: Design a double riveted lap joint for MS Plates having a thickness 9.5 mm. Calculate the efficiency of the joint. The permissible stresses are: $\sigma_t = 90 \text{ MPa}$, $\tau_s = 75 \text{ MPa}$, $\sigma_c = 150 \text{ MPa}$.

Design of boiler joints according to IBR

The boiler has a longitudinal joint as well as circumferential joint. The longitudinal joint is used to join the ends of the plate to get the required diameter of a boiler. For this purpose, a butt joint with two cover plates is used. The circumferential joint is used to get the required length of the boiler. For this purpose, a lap joint with one ring overlapping the other alternately is used.

Since a boiler is made up of number of rings, therefore the longitudinal joints are staggered for convenience of connecting rings at places where both longitudinal and circumferential joints occur.

Design of Longitudinal Butt Joint for a Boiler

According to Indian Boiler Regulations (I.B.R), the following procedure should be adopted for the design of longitudinal butt joint for a boiler.

1. Thickness of boiler shell.

First of all, the thickness of the boiler shell is determined by using the thin cylindrical formula, i.e.

$$t = \frac{PD}{2\sigma_t \times \eta_l} + 1 \text{ mm as corrosion allowance}$$

Where t = Thickness of the boiler shell,
 P = Steam pressure in boiler,
 D = Internal diameter of boiler
 σ_t = Permissible tensile stress, and
 η_l = Efficiency of the longitudinal joint.

The following points may be noted:

- (a) The thickness of the boiler shell should not be less than 7 mm.
- (b) The efficiency of the joint may be taken from the following table.

Indian Boiler Regulations (I.B.R.) allows a maximum efficiency of 85% for the best joint.

- (c) According to I.B.R., the factor of safety should not be less than 4.

2. Diameter of rivets.

After finding out the thickness of the boiler shell (t), the diameter of the rivet hole (d) may be determined by using Unwin's empirical formula,

$$\text{i.e. } d = 6\sqrt{t} \quad , \text{ (when } t \text{ is greater than } 8 \text{ mm)}$$

But if the thickness of plate is less than 8 mm, then the diameter of the rivet hole may be calculated by equating the shearing resistance of the rivets to crushing resistance. In no case, the diameter of rivet hole should not be less than the thickness of the plate, because there will be danger of punch crushing.

3. Pitch of rivets.

The pitch of the rivets is obtained by equating the tearing resistance of the plate to the shearing resistance of the rivets. It may be noted that;

- (a) The pitch of the rivets should not be less than $2d$, which is necessary for the formation of head.

(b) The maximum value of the pitch of rivets for a longitudinal joint of a boiler as per I.B.R. is

$$p_{\max} = C \times t + 41.28 \text{ mm}$$

where, t = Thickness of the shell plate in mm,

C = Constant.

- The value of the constant C may be taken from DDB. If the pitch of rivets as obtained by equating the tearing resistance to the shearing resistance is more than p_{\max} , then the value of p_{\max} is taken.

4. Distance between the rows of rivets.

The distance between the rows of rivets as specified by Indian Boiler Regulations is as follows:

(a) For equal number of rivets in more than one row for lap joint or butt joint, the distance between the rows of rivets (p_b) should not be less than

$$\begin{aligned} & \mathbf{0.33 p + 0.67 d} \text{for zig-zig riveting, and} \\ & \mathbf{2d} \text{for chain riveting.} \end{aligned}$$

(b) For joints in which the number of rivets in outer rows is **half** the number of rivets in inner rows and if the inner rows are chain riveted, the distance between the outer rows and the next rows should not be less than **0.33 p + 0.67 d** or **2d**, whichever is greater.

The distance between the rows in which there are full number of rivets shall not be less than $2d$.

(c) For joints in which the number of rivets in outer rows is **half** the number of rivets in inner rows and if the inner rows are zig-zig riveted, the distance between the outer rows and the next rows shall not be less than $0.2 p + 1.15 d$. The distance between the rows in which there are full number of rivets (zig-zag) shall not be less than **0.165 p + 0.67d**.

Note : In the above discussion, p is the pitch of the rivets in the outer rows.

5. Thickness of butt strap.

According to I.B.R., the thicknesses for butt strap (t_1) are as given below:

- (a) The thickness of butt strap, in no case, shall be less than 10 mm.
- (b) $t_1 = 1.125 t$, for ordinary (chain riveting) single butt strap.

$$t_1 = 1.125 t \left(\frac{p - d}{p - 2d} \right)$$

For single butt straps, every alternate rivet in outer rows being omitted.

$t_1 = 0.625 t$, for double butt-straps of equal width having ordinary riveting (chain riveting).

$$t_1 = 0.625 t \left(\frac{p - d}{p - 2d} \right)$$

For double butt straps of equal width having every alternate rivet in the outer rows being omitted.

- (c) For unequal width of butt straps, the thicknesses of butt strap are

$t_1 = 0.75 t$, for wide strap on the inside, and

$t_1 = 0.625 t$, for narrow strap on the outside.

6. Margin.

The margin (m) is taken as $1.5 d$.

Q.1: Inner diameter of a boiler is 1500 mm and the steam pressure is 2 N/mm². Use a proper joint along the length and design it completely. Use following permissible values of stress.

Tension $\sigma_t = 90$ MPa, Shear $\tau = 75$ MPa , Crushing $\sigma_c = 150$ MPa

Q.2: A cylindrical pressure vessel with a 1.5 m inside diameter is subjected to internal steam pressure of 1.5 MPa. It is made from steel plate by triple-riveted double strap longitudinal butt joint with equal straps. The pitch of the rivets in the outer row is twice of the pitch of the rivets in the inner rows. The rivets are arranged in a zig zag pattern. The efficiency of the riveted joint should be atleast 80 %. The permissible stresses for the plate and rivets in tension, shear and compression are 80, 60 and 120 MPa, respectively. Assume that the rivet in double shear is 1.875 times stronger than in single shear. Design the joint and calculate

1. thickness of the plate,
2. diameter of the rivets,
3. Pitch of the rivets,
4. distance between the rows of rivets,
5. margin
6. thickness of the straps and
7. Efficiency of the joint.

Chapter-3

DESIGN OF SHAFTS AND KEYS

Shafts:

A shaft is a rotating machine element which is used to transmit power from one place to another. The power is delivered to the shaft by some tangential force and the resultant torque (or twisting moment) set up within the shaft permits the power to be transferred to various machines linked up to the shaft. In order to transfer the power from one shaft to another, the various members such as pulleys, gears etc., are mounted on it. These members along with the forces exerted upon them causes the shaft to bend.

In other words, we may say that a shaft is used for the transmission of torque and bending moment. The various members are mounted on the shaft by means of keys or splines. The shafts are usually cylindrical, but may be square or cross-shaped in section. They are solid in cross-section but sometimes hollow shafts are also used. An **axle**, though similar in shape to the shaft, is a stationary machine element and is used for the transmission of bending moment only. It simply acts as a support for some rotating body such as hoisting drum, a car wheel or a rope sheave. A **spindle** is a short shaft that imparts motion either to a cutting tool (*e.g.* drill press spindles) or to a work piece (*e.g.* lathe spindles).

Types of Shafts

The following two types of shafts are important from the subject point of view:

Transmission shafts. These shafts transmit power between the source and the machines absorbing power. The counter shafts, line shafts, over head shafts and all factory shafts are transmission shafts. Since these shafts carry machine parts such as pulleys, gears etc., therefore they are subjected to bending in addition to twisting.

Machine shafts. These shafts form an integral part of the machine itself. The crank shaft is an example of machine shaft.

Stresses in Shafts

The following stresses are induced in the shafts:

Shear stresses due to the transmission of torque (*i.e.* due to torsional load).

Bending stresses (tensile or compressive) due to the forces acting upon machine elements like gears, pulleys etc. as well as due to the weight of the shaft itself.

Stresses due to combined torsional and bending loads.

Design of Shafts

The shafts may be designed on the basis of

1. Strength, and
2. Rigidity and stiffness.

In designing shafts on the basis of strength, the following cases may be considered:

- (a) Shafts subjected to twisting moment or torque only,
- (b) Shafts subjected to bending moment only,
- (c) Shafts subjected to combined twisting and bending moments, and
- (d) Shafts subjected to axial loads in addition to combined torsional and bending loads.

Shafts Subjected to Twisting Moment Only

Solid shaft:

When the shaft is subjected to a twisting moment (or torque) only, then the diameter of the shaft may be obtained by using the torsion equation. We know that

$$\frac{T}{J} = \frac{\tau}{r}$$

Where T = Twisting moment (or torque) acting upon the shaft,

J = Polar moment of inertia of the shaft about the axis of rotation,

τ = Torsional shear stress, and

r = Distance from neutral axis to the outer most fibre

= $d / 2$; where d is the diameter of the shaft.

We know that for round solid shaft, polar moment of inertia,

$$J = \frac{\pi}{32} d^4$$

Then we get,
$$T = \frac{\pi d^3}{16} \tau$$

From this equation, diameter of the solid shaft (d) may be obtained.

Hollow shaft:

We also know that for hollow shaft, polar moment of inertia,

$$J = \frac{\pi}{32} [(d_o)^4 - (d_i)^4]$$

Where d_o and d_i = Outside and inside diameter of the shaft, and $r = d_o / 2$.

Substituting these values in equation (i), we have

$$\frac{T}{\frac{\pi}{32} [(d_o)^4 - (d_i)^4]} = \frac{\tau}{\frac{d_o}{2}} \quad \text{or} \quad T = \frac{\pi}{16} \times \tau \left[\frac{(d_o)^4 - (d_i)^4}{d_o} \right]$$

Let k = Ratio of inside diameter and outside diameter of the shaft = d_i / d_o

Now the equation (iii) may be written as

$$T = \frac{\pi}{16} \times \tau \times \frac{(d_o)^4}{d_o} \left[1 - \left(\frac{d_i}{d_o} \right)^4 \right] = \frac{\pi}{16} \times \tau (d_o)^3 (1 - k^4)$$

From the equations, the outside and inside diameter of a hollow shaft may be determined.

It may be noted that

1. The hollow shafts are usually used in marine work. These shafts are stronger per kg of material and they may be forged on a mandrel, thus making the material more homogeneous than would be possible for a solid shaft. When a hollow shaft is to be made equal in strength to a solid shaft, the twisting moment of both the shafts must be same. In other words, for the same material of both the shafts,

$$T = \frac{\pi}{16} \times \tau \left[\frac{(d_o)^4 - (d_i)^4}{d_o} \right] = \frac{\pi}{16} \times \tau \times d^3$$

$$\therefore \frac{(d_o)^4 - (d_i)^4}{d_o} = d^3 \quad \text{or} \quad (d_o)^3 (1 - k^4) = d^3$$

2. The twisting moment (T) may be obtained by using the following relation:

We know that the power transmitted (in watts) by the shaft,

$$P = \frac{2\pi N \times T}{60} \quad \text{or} \quad T = \frac{P \times 60}{2\pi N}$$

Where T = Twisting moment in N-m, and

N = Speed of the shaft in r.p.m.

3. In case of belt drives, the twisting moment (T) is given by

$$T = (T_1 - T_2) R$$

Where T_1 and T_2 = Tensions in the tight side and slack side of the belt respectively, and R = Radius of the pulley.

Shafts Subjected to Bending Moment Only

a) Solid Shaft:

When the shaft is subjected to a bending moment only, then the maximum stress (tensile or compressive) is given by the bending equation. We know that

Where M = Bending moment,

$$\frac{M}{I} = \frac{\sigma_b}{y}$$

I = Moment of inertia of cross-sectional area of the shaft about the axis of rotation,

σ_b = Bending stress, and

y = Distance from neutral axis to the outer-most fibre.

We know that for a round solid shaft, moment of inertia,

$$I = \frac{\pi}{64} \times d^4 \quad \text{and} \quad y = \frac{d}{2}$$

Substituting these values in equation

$$\frac{M}{\frac{\pi}{64} \times d^4} = \frac{\sigma_b}{\frac{d}{2}} \quad \text{or} \quad M = \frac{\pi}{32} \times \sigma_b \times d^3$$

From this equation, diameter of the solid shaft (d) may be obtained.

b) Hollow Shaft:

We also know that for a hollow shaft, moment of inertia,

$$I = \frac{\pi}{64} [(d_o)^4 - (d_i)^4] = \frac{\pi}{64} (d_o)^4 (1 - k^4) \quad \dots(\text{where } k = d_i / d_o)$$

And $y = d_o / 2$

Again substituting these values in equation, we have

$$\frac{M}{\frac{\pi}{64} (d_o)^4 (1 - k^4)} = \frac{\sigma_b}{\frac{d_o}{2}} \quad \text{or} \quad M = \frac{\pi}{32} \times \sigma_b (d_o)^3 (1 - k^4)$$

From this equation, the outside diameter of the shaft (d_o) may be obtained.

Shafts Subjected to Combined Twisting Moment and Bending Moment

When the shaft is subjected to combined twisting moment and bending moment, then the shaft must be designed on the basis of the two moments simultaneously. Various theories have been suggested to account for the elastic failure of the materials when they are subjected to various types of combined stresses. The following two theories are important from the subject point of view:

1. Maximum shear stress theory or Guest's theory: It is used for ductile materials such as mild steel.
2. Maximum normal stress theory or Rankine's theory : It is used for brittle materials such as cast iron.

Let τ = Shear stress induced due to twisting moment, and

σ_b = Bending stress (tensile or compressive) induced due to bending moment.

a) Solid Shaft:

According to maximum shear stress theory, the maximum shear stress in the shaft,

$$\tau_{max} = \frac{1}{2} \sqrt{(\sigma_b)^2 + 4\tau^2}$$

Substituting the values of σ_b and τ

$$\tau_{max} = \frac{1}{2} \sqrt{\left(\frac{32M}{\pi d^3}\right)^2 + 4\left(\frac{16T}{\pi d^3}\right)^2} = \frac{16}{\pi d^3} \left[\sqrt{M^2 + T^2}\right]$$

$$\text{or} \quad \frac{\pi}{16} \times \tau_{max} \times d^3 = \sqrt{M^2 + T^2}$$

$$T_e = \sqrt{M^2 + T^2} = \frac{\pi}{16} \times \tau \times d^3$$

The expression T_e

is known as **equivalent twisting moment** and is denoted by T_e .

The equivalent twisting moment may be defined as that twisting moment, which when acting alone, produces the same shear stress (τ) as the actual twisting moment. By limiting the maximum shear stress (τ_{max}) equal to the allowable shear stress (τ) for the material, the equation (i) may be written as

$$T_e = \sqrt{M^2 + T^2} = \frac{\pi}{16} \times \tau \times d^3$$

From this expression, diameter of the shaft (d) may be evaluated.

Now according to maximum normal stress theory, the maximum normal stress in the shaft,

$$\begin{aligned} \sigma_{b(max)} &= \frac{1}{2} \sigma_b + \frac{1}{2} \sqrt{(\sigma_b)^2 + 4\tau^2} \\ &= \frac{1}{2} \times \frac{32M}{\pi d^3} + \frac{1}{2} \sqrt{\left(\frac{32M}{\pi d^3}\right)^2 + 4\left(\frac{16T}{\pi d^3}\right)^2} \\ &= \frac{32}{\pi d^3} \left[\frac{1}{2} (M + \sqrt{M^2 + T^2}) \right] \end{aligned}$$

$$\text{or} \quad \frac{\pi}{32} \times \sigma_{b(max)} \times d^3 = \frac{1}{2} [M + \sqrt{M^2 + T^2}]$$

the

The above expression is known as **equivalent bending moment** (M_e).

$$M_e = \frac{1}{2} [M + \sqrt{M^2 + T^2}] = \frac{\pi}{32} \times \sigma_b \times d^3$$

b) Hollow shaft:

$$T_e = \sqrt{M^2 + T^2} = \frac{\pi}{16} \times \tau (d_o)^3 (1 - k^4)$$

$$M_e = \frac{1}{2} (M + \sqrt{M^2 + T^2}) = \frac{\pi}{32} \times \sigma_b (d_o)^3 (1 - k^4)$$

It is suggested that diameter of the shaft may be obtained by using both the theories and the larger of the two values is adopted.

A shaft is supported by two bearings placed 1 m apart. A 600 mm diameter pulley is mounted at a distance of 300 mm to the right of left hand bearing and this drives a pulley directly below it with the help of belt having maximum tension of 2.25 kN. Another pulley 400 mm diameter is placed 200 mm to the left of right hand bearing and is driven with the help of electric motor and belt, which is placed horizontally to the

right. The angle of contact for both the pulleys is 180° and $\mu = 0.24$. Determine the suitable diameter for a solid shaft, allowing working stress of 63 MPa in tension and 42 MPa in shear for the material of shaft. Assume that the torque on one pulley is equal to that on the other pulley.

Solution. Given : $AB = 800 \text{ mm}$; $\alpha_C = 20^\circ$; $D_C = 600 \text{ mm}$ or $R_C = 300 \text{ mm}$; $AC = 200 \text{ mm}$; $D_D = 700 \text{ mm}$ or $R_D = 350 \text{ mm}$; $DB = 250 \text{ mm}$; $\theta = 180^\circ = \pi \text{ rad}$; $W = 2000 \text{ N}$; $T_1 = 3000 \text{ N}$; $T_1/T_2 = 3$; $\tau = 40 \text{ MPa} = 40 \text{ N/mm}^2$

The space diagram of the shaft is shown in Fig (a).

We know that the torque acting on the shaft at D ,

$$\begin{aligned} T &= (T_1 - T_2) R_D = T_1 \left(1 - \frac{T_2}{T_1} \right) R_D \\ &= 3000 \left(1 - \frac{1}{3} \right) 350 = 700 \times 10^3 \text{ N-mm} \quad \dots (\because T_1/T_2 = 3) \end{aligned}$$

The torque diagram is shown in Fig. (b).

Assuming that the torque at D is equal to the torque at C , therefore the tangential force acting on the gear C ,

$$F_{tc} = \frac{T}{R_C} = \frac{700 \times 10^3}{300} = 2333 \text{ N}$$

and the normal load acting on the tooth of gear C ,

$$W_C = \frac{F_{tc}}{\cos \alpha_C} = \frac{2333}{\cos 20^\circ} = \frac{2333}{0.9397} = 2483 \text{ N}$$

The normal load acts at 20° to the vertical as shown in Fig.

Resolving the normal load vertically and horizontally, we get

Vertical component of W_C i.e. the vertical load acting on the shaft at C ,

$$\begin{aligned} W_{CV} &= W_C \cos 20^\circ \\ &= 2483 \times 0.9397 = 2333 \text{ N} \end{aligned}$$

and horizontal component of W_C i.e. the horizontal load acting on the shaft at C ,

$$\begin{aligned} W_{CH} &= W_C \sin 20^\circ \\ &= 2483 \times 0.342 = 849 \text{ N} \end{aligned}$$

Since $T_1/T_2 = 3$ and $T_1 = 3000 \text{ N}$, therefore

$$T_2 = T_1 / 3 = 3000 / 3 = 1000 \text{ N}$$

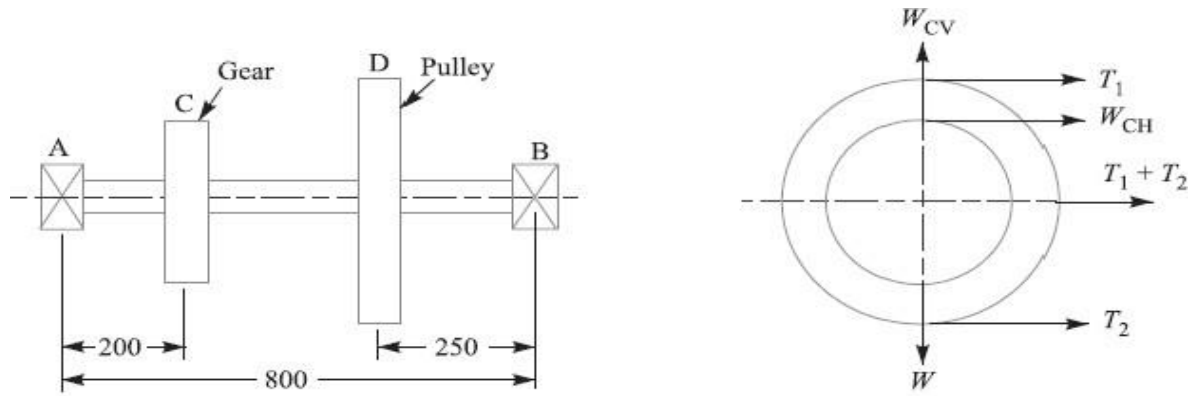

All dimensions in mm.

(a) Space diagram.

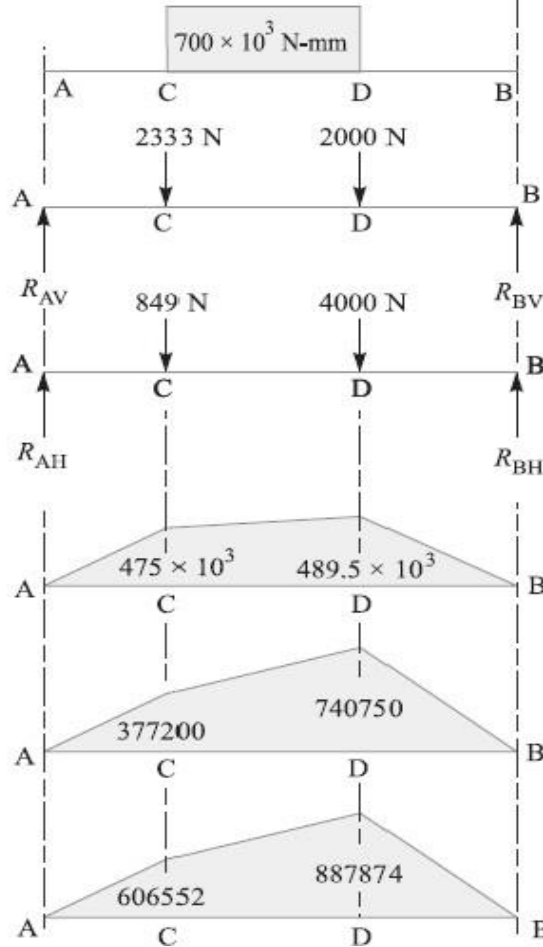

(b) Torque diagram.

(c) Vertical load diagram.

(d) Horizontal load diagram.

(e) Vertical B.M. diagram.

(f) Horizontal B.M. diagram.

(g) Resultant B.M. diagram.

∴ Horizontal load acting on the shaft at D ,

$$W_{DH} = T_1 + T_2 = 3000 + 1000 = 4000 \text{ N}$$

and vertical load acting on the shaft at D ,

$$W_{DV} = W = 2000 \text{ N}$$

The vertical and horizontal load diagram at C and D is shown in Fig. 14.6 (c) and (d) respectively.

Now let us find the maximum bending moment for vertical and horizontal loading.

First of all considering the vertical loading at C and D . Let R_{AV} and R_{BV} be the reactions at the bearings A and B respectively. We know that

$$R_{AV} + R_{BV} = 2333 + 2000 = 4333 \text{ N}$$

Taking moments about A , we get

$$\begin{aligned} R_{BV} \times 800 &= 2000(800 - 250) + 2333 \times 200 \\ &= 1\,566\,600 \end{aligned}$$

$$\therefore R_{BV} = 1\,566\,600 / 800 = 1958 \text{ N}$$

and

$$R_{AV} = 4333 - 1958 = 2375 \text{ N}$$

We know that B.M. at A and B ,

$$M_{AV} = M_{BV} = 0$$

$$\begin{aligned} \text{B.M. at } C, \quad M_{CV} &= R_{AV} \times 200 = 2375 \times 200 \\ &= 475 \times 10^3 \text{ N-mm} \end{aligned}$$

$$\text{B.M. at } D, \quad M_{DV} = R_{BV} \times 250 = 1958 \times 250 = 489.5 \times 10^3 \text{ N-mm}$$

The bending moment diagram for vertical loading is shown in Fig. 14.6 (e).

Now consider the horizontal loading at C and D . Let R_{AH} and R_{BH} be the reactions at the bearings A and B respectively. We know that

$$R_{AH} + R_{BH} = 849 + 4000 = 4849 \text{ N}$$

Taking moments about A , we get

$$R_{BH} \times 800 = 4000(800 - 250) + 849 \times 200 = 2\,369\,800$$

$$\therefore R_{BH} = 2\,369\,800 / 800 = 2963 \text{ N}$$

and

$$R_{AH} = 4849 - 2963 = 1886 \text{ N}$$

We know that B.M. at A and B ,

$$M_{AH} = M_{BH} = 0$$

$$\text{B.M. at } C, \quad M_{CH} = R_{AH} \times 200 = 1886 \times 200 = 377\,200 \text{ N-mm}$$

$$\text{B.M. at } D, \quad M_{DH} = R_{BH} \times 250 = 2963 \times 250 = 740\,750 \text{ N-mm}$$

The bending moment diagram for horizontal loading is shown in Fig. 14.6 (f).

We know that resultant B.M. at C ,

$$\begin{aligned} M_C &= \sqrt{(M_{CV})^2 + (M_{CH})^2} = \sqrt{(475 \times 10^3)^2 + (377\,200)^2} \\ &= 606\,552 \text{ N-mm} \end{aligned}$$

and resultant B.M. at D ,

$$\begin{aligned} M_D &= \sqrt{(M_{DV})^2 + (M_{DH})^2} = \sqrt{(489.5 \times 10^3)^2 + (740\,750)^2} \\ &= 887\,874 \text{ N-mm} \end{aligned}$$

Maximum bending moment

The resultant B.M. diagram is shown in Fig. 14.6 (g). We see that the bending moment is maximum at D , therefore

$$\text{Maximum B.M.,} \quad M = M_D = 887\,874 \text{ N-mm Ans.}$$

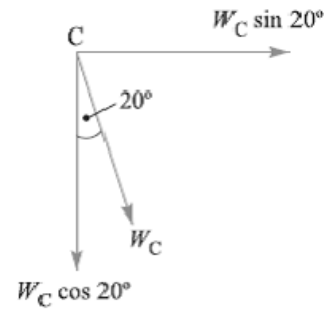

Fig. 14.7

Diameter of the shaft

Let d = Diameter of the shaft.

We know that the equivalent twisting moment,

$$T_e = \sqrt{M^2 + T^2} = \sqrt{(887\ 874)^2 + (700 \times 10^3)^2} = 1131 \times 10^3 \text{ N-mm}$$

We also know that equivalent twisting moment (T_e),

$$1131 \times 10^3 = \frac{\pi}{16} \times \tau \times d^3 = \frac{\pi}{16} \times 40 \times d^3 = 7.86 d^3$$

$$\therefore d^3 = 1131 \times 10^3 / 7.86 = 144 \times 10^3 \quad \text{or} \quad d = 52.4 \text{ say } 55 \text{ mm Ans.}$$

A steel solid shaft transmitting 15 kW at 200 r.p.m. is supported on two bearings 750 mm apart and has two gears keyed to it. The pinion having 30 teeth of 5 mm module is located 100 mm to the left of the right hand bearing and delivers power horizontally to the right. The gear having 100 teeth of 5 mm module is located 150 mm to the right of the left hand bearing and receives power in a vertical direction from below. Using an allowable stress of 54 MPa in shear, determine the diameter of the shaft.

Solution. Given : $P = 15 \text{ kW} = 15 \times 10^3 \text{ W}$; $N = 200 \text{ r.p.m.}$; $AB = 750 \text{ mm}$; $T_D = 30$; $m_D = 5 \text{ mm}$; $BD = 100 \text{ mm}$; $T_C = 100$; $m_C = 5 \text{ mm}$; $AC = 150 \text{ mm}$; $\tau = 54 \text{ MPa} = 54 \text{ N/mm}^2$

The space diagram of the shaft is shown in Fig. 14.8 (a).

We know that the torque transmitted by the shaft,

$$T = \frac{P \times 60}{2\pi N} = \frac{15 \times 10^3 \times 60}{2\pi \times 200} = 716 \text{ N-m} = 716 \times 10^3 \text{ N-mm}$$

The torque diagram is shown in Fig. 14.8 (b).

We know that diameter of gear

$$= \text{No. of teeth on the gear} \times \text{module}$$

\therefore Radius of gear C ,

$$R_C = \frac{T_C \times m_C}{2} = \frac{100 \times 5}{2} = 250 \text{ mm}$$

and radius of pinion D ,

$$R_D = \frac{T_D \times m_D}{2} = \frac{30 \times 5}{2} = 75 \text{ mm}$$

Assuming that the torque at C and D is same (i.e. $716 \times 10^3 \text{ N-mm}$), therefore tangential force on the gear C , acting downward,

$$F_{tC} = \frac{T}{R_C} = \frac{716 \times 10^3}{250} = 2870 \text{ N}$$

and tangential force on the pinion D , acting horizontally,

$$F_{tD} = \frac{T}{R_D} = \frac{716 \times 10^3}{75} = 9550 \text{ N}$$

The vertical and horizontal load diagram is shown in Fig. 14.8 (c) and (d) respectively.

Now let us find the maximum bending moment for vertical and horizontal loading.

First of all, considering the vertical loading at C. Let R_{AV} and R_{BV} be the reactions at the bearings A and B respectively. We know that

$$R_{AV} + R_{BV} = 2870 \text{ N}$$

Taking moments about A, we get

$$R_{BV} \times 750 - 2870 \times 150$$

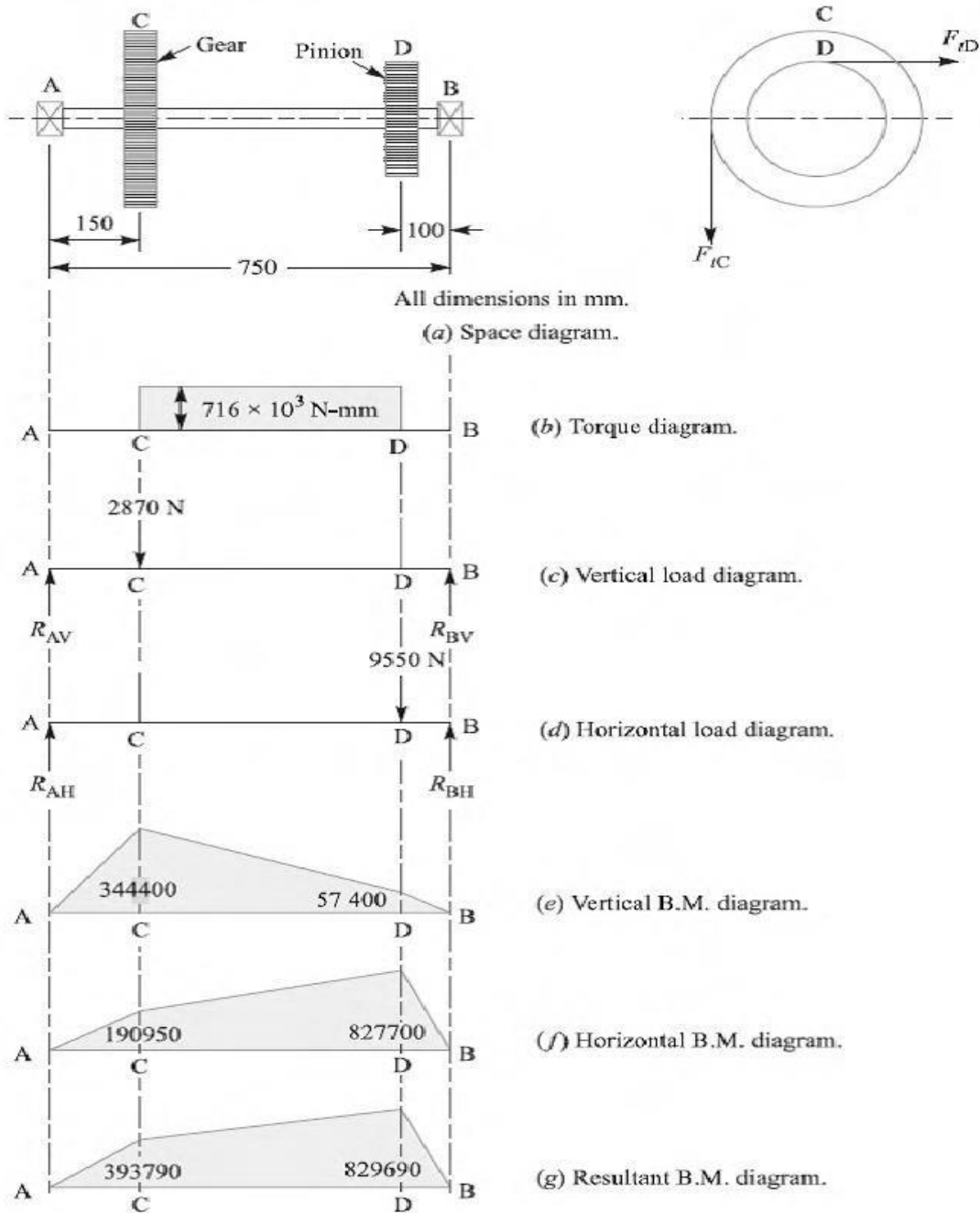

$$\therefore R_{BV} = 2870 \times 150 / 750 = 574 \text{ N}$$

and $R_{AV} = 2870 - 574 = 2296 \text{ N}$

We know that B.M. at A and B ,

$$M_{AV} = M_{BV} = 0$$

B.M. at C , $M_{CV} = R_{AV} \times 150 = 2296 \times 150 = 344\,400 \text{ N-mm}$

B.M. at D , $M_{DV} = R_{BV} \times 100 = 574 \times 100 = 57\,400 \text{ N-mm}$

The B.M. diagram for vertical loading is shown in Fig. 14.8 (e).

Now considering horizontal loading at D . Let R_{AH} and R_{BH} be the reactions at the bearings A and B respectively. We know that

$$R_{AH} + R_{BH} = 9550 \text{ N}$$

Taking moments about A , we get

$$R_{BH} \times 750 = 9550 (750 - 100) = 9550 \times 650$$

$$\therefore R_{BH} = 9550 \times 650 / 750 = 8277 \text{ N}$$

and $R_{AH} = 9550 - 8277 = 1273 \text{ N}$

We know that B.M. at A and B ,

$$M_{AH} = M_{BH} = 0$$

B.M. at C , $M_{CH} = R_{AH} \times 150 = 1273 \times 150 = 190\,950 \text{ N-mm}$

B.M. at D , $M_{DH} = R_{BH} \times 100 = 8277 \times 100 = 827\,700 \text{ N-mm}$

The B.M. diagram for horizontal loading is shown in Fig. 14.8 (f).

We know that resultant B.M. at C ,

$$M_C = \sqrt{(M_{CV})^2 + (M_{CH})^2} = \sqrt{(344\,400)^2 + (190\,950)^2} \\ = 393\,790 \text{ N-mm}$$

and resultant B.M. at D ,

$$M_D = \sqrt{(M_{DV})^2 + (M_{DH})^2} = \sqrt{(57\,400)^2 + (827\,700)^2} \\ = 829\,690 \text{ N-mm}$$

The resultant B.M. diagram is shown in Fig. 14.8 (g). We see that the bending moment is maximum at D .

\therefore Maximum bending moment,

$$M = M_D = 829\,690 \text{ N-mm}$$

Let d = Diameter of the shaft.

We know that the equivalent twisting moment,

$$T_e = \sqrt{M^2 + T^2} = \sqrt{(829\,690)^2 + (716 \times 10^3)^2} = 1096 \times 10^3 \text{ N-mm}$$

We also know that equivalent twisting moment (T_e),

$$1096 \times 10^3 = \frac{\pi}{16} \times \tau \times d^3 = \frac{\pi}{16} \times 54 \times d^3 = 10.6 d^3$$

$$\therefore d^3 = 1096 \times 10^3 / 10.6 = 103.4 \times 10^3$$

or $d = 47$ say 50 mm Ans.

Shafts Subjected to Axial Load in addition to Combined Torsion and Bending Loads:

When the shaft is subjected to an axial load (F) in addition to torsion and bending loads as in propeller shafts of ships and shafts for driving worm gears, then the stress due to axial load must be added to the bending stress (σ_b). We know that bending equation is

$$\frac{M}{I} = \frac{\sigma_b}{y} \quad \text{or} \quad \sigma_b = \frac{M \cdot y}{I} = \frac{M \times d/2}{\frac{\pi}{64} \times d^4} = \frac{32M}{\pi d^3}$$

And stress due to axial load

$$= \frac{F}{\frac{\pi}{4} \times d^2} = \frac{4F}{\pi d^2} \quad \dots(\text{For round solid shaft})$$

$$= \frac{F}{\frac{\pi}{4} [(d_o)^2 - (d_i)^2]} = \frac{4F}{\pi [(d_o)^2 - (d_i)^2]} \quad \dots(\text{For hollow shaft})$$

$$= \frac{F}{\pi (d_o)^2 (1 - k^2)} \quad \dots (\because k = d_i/d_o)$$

Resultant stress (tensile or compressive) for solid shaft,

$$\sigma_1 = \frac{32M}{\pi d^3} + \frac{4F}{\pi d^2} = \frac{32}{\pi d^3} \left(M + \frac{F \times d}{8} \right) \quad \dots(i)$$

$$= \frac{32M_1}{\pi d^3} \quad \dots \left(\text{Substituting } M_1 = M + \frac{F \times d}{8} \right)$$

In case of a hollow shaft, the resultant stress,

$$\begin{aligned} \sigma_1 &= \frac{32M}{\pi (d_o)^3 (1 - k^4)} + \frac{4F}{\pi (d_o)^2 (1 - k^2)} \\ &= \frac{32}{\pi (d_o)^3 (1 - k^4)} \left[M + \frac{F d_o (1 + k^2)}{8} \right] = \frac{32M_1}{\pi (d_o)^3 (1 - k^4)} \end{aligned}$$

In case of long shafts (slender shafts) subjected to compressive loads, a factor known as **column factor** (α) must be introduced to take the column effect into account.

Therefore, Stress due to the compressive load,

$$\begin{aligned} \sigma_c &= \frac{\alpha \times 4F}{\pi d^2} \\ \text{Or} \\ &= \frac{\alpha \times 4F}{\pi (d_o)^2 (1 - k^2)} \end{aligned}$$

The value of column factor (α) for compressive loads* may be obtained from the following relation :

Column factor,

$$\alpha = \frac{1}{1 - 0.0044 (L/K)^2}$$

This expression is used when the slenderness ratio (L / K) is less than 115. When the slenderness ratio (L / K) is more than 115, then the value of column factor may be obtained from the following relation:

Column factor, α

$$\alpha = \frac{\sigma_y (L/K)^2}{C \pi^2 E}$$

Where L = Length of shaft between the bearings,

K = Least radius of gyration,

σ_y = Compressive yield point stress of shaft material, and

C = Coefficient in Euler's formula depending upon the end conditions. The

following are the different values of C depending upon the end conditions.

$C = 1$, for hinged ends,

= 2.25, for fixed ends,

= 1.6, for ends that are partly restrained as in bearings.

In general, for a hollow shaft subjected to fluctuating torsional and bending load, along with an axial load, the equations for equivalent twisting moment (T_e) and equivalent bending moment (M_e) may be written as

$$T_e = \sqrt{\left[K_m \times M + \frac{\alpha F d_o (1 + k^2)}{8} \right]^2 + (K_t \times T)^2}$$

$$= \frac{\pi}{16} \times \tau (d_o)^3 (1 - k^4)$$

$$M_e = \frac{1}{2} \left[K_m \times M + \frac{\alpha F d_o (1 + k^2)}{8} + \sqrt{\left\{ K_m \times M + \frac{\alpha F d_o (1 + k^2)}{8} \right\}^2 + (K_t \times T)^2} \right]$$

$$= \frac{\pi}{32} \times \sigma_b (d_o)^3 (1 - k^4)$$

It may be noted that for a solid shaft, $k = 0$ and $d_o = d$ when the shaft carries no axial load, then $F = 0$ and when the shaft carries axial tensile load, then $\alpha = 1$.

A hollow shaft is subjected to a maximum torque of 1.5 kN-m and a maximum bending moment of 3 kN-m. It is subjected, at the same time, to an axial load of 10 kN. Assume that the load is applied gradually and the ratio of the inner diameter to the outer diameter is 0.5. If the outer diameter of the shaft is 80 mm, find the shear stress induced in the shaft.

Solution. Given: $T = 1.5 \text{ kN-m} = 1.5 \times 10^3 \text{ N-m}$; $M = 3 \text{ kN-m} = 3 \times 10^3 \text{ N-m}$; $F = 10 \text{ kN} = 10 \times 10^3 \text{ N}$; $k = d_i / d_o = 0.5$; $d_o = 80 \text{ mm} = 0.08 \text{ m}$

Let τ = Shear stress induced in the shaft.

Since the load is applied gradually, therefore from DDB, we find that $K_m = 1.5$; and $K_t = 1.0$ We know that the equivalent twisting moment for a hollow shaft,

$$T_e = \sqrt{\left[K_m \times M + \frac{\alpha F d_o (1 + k^2)^2}{8} \right]^2 + (K_t \times T)^2}$$

$$= \sqrt{\left[1.5 \times 3 \times 10^3 + \frac{1 \times 10 \times 10^3 \times 0.08 (1 + 0.5^2)^2}{8} \right]^2 + (1 \times 1.5 \times 10^3)^2}$$

$$= \sqrt{(4500 + 125)^2 + (1500)^2} = 4862 \text{ N-m} = 4862 \times 10^3 \text{ N-mm}$$

We also know that the equivalent twisting moment for a hollow shaft (T_e),

$$4862 \times 10^3 = \frac{\pi}{16} \times \tau (d_o)^3 (1 - k^4) = \frac{\pi}{16} \times \tau (80)^3 (1 - 0.5^4) = 94\,260 \tau$$

$$\therefore \tau = 4862 \times 10^3 / 94\,260 = 51.6 \text{ N/mm}^2 = 51.6 \text{ MPa Ans.}$$

A hollow shaft of 0.5 m outside diameter and 0.3 m inside diameter is used to drive a propeller of a marine vessel. The shaft is mounted on bearings 6 metre apart and it transmits 5600 kW at 150

r.p.m. The maximum axial propeller thrust is 500 kN and the shaft weighs 70 kN.

Determine:

1. The maximum shear stress developed in the shaft, and
2. The angular twist between the bearings

Solution. Given : $d_o = 0.5 \text{ m}$; $d_i = 0.3 \text{ m}$; $P = 5600 \text{ kW} = 5600 \times 10^3 \text{ W}$; $L = 6 \text{ m}$; $N = 150 \text{ r.p.m.}$; $F = 500 \text{ kN} = 500 \times 10^3 \text{ N}$; $W = 70 \text{ kN} = 70 \times 10^3 \text{ N}$

1. Maximum shear stress developed in the shaft

Let τ = Maximum shear stress developed in the shaft.

We know that the torque transmitted by the shaft,

$$T = \frac{P \times 60}{2\pi N} = \frac{5600 \times 10^3 \times 60}{2\pi \times 150} = 356\,460 \text{ N-m}$$

and the maximum bending moment,

$$M = \frac{W \times L}{8} = \frac{70 \times 10^3 \times 6}{8} = 52\,500 \text{ N-m}$$

Now let us find out the column factor α . We know that least radius of gyration,

$$\begin{aligned} K &= \sqrt{\frac{I}{A}} = \sqrt{\frac{\frac{\pi}{64} [(d_o)^4 - (d_i)^4]}{\frac{\pi}{4} [(d_o)^2 - (d_i)^2]}} \\ &= \sqrt{\frac{[(d_o)^2 + (d_i)^2][(d_o)^2 - (d_i)^2]}{16 [(d_o)^2 - (d_i)^2]}} \\ &= \frac{1}{4} \sqrt{(d_o)^2 + (d_i)^2} = \frac{1}{4} \sqrt{(0.5)^2 + (0.3)^2} = 0.1458 \text{ m} \end{aligned}$$

\therefore Slenderness ratio,

$$L / K = 6 / 0.1458 = 41.15$$

and column factor,

$$\begin{aligned} \alpha &= \frac{1}{1 - 0.0044 \left(\frac{L}{K}\right)} \quad \dots \left(\because \frac{L}{K} < 115\right) \\ &= \frac{1}{1 - 0.0044 \times 41.15} = \frac{1}{1 - 0.18} = 1.22 \end{aligned}$$

Assuming that the load is applied gradually, therefore from Table 14.2, we find that

$$K_m = 1.5 \text{ and } K_t = 1.0$$

Also $k = d_i / d_o = 0.3 / 0.5 = 0.6$

We know that the equivalent twisting moment for a hollow shaft,

$$\begin{aligned} T_e &= \sqrt{\left[K_m \times M + \frac{\alpha F d_o (1 + k^2)}{8} \right]^2 + (K_t \times T)^2} \\ &= \sqrt{\left[1.5 \times 52\,500 + \frac{1.22 \times 500 \times 10^3 \times 0.5 (1 + 0.6^2)}{8} \right]^2 + (1 \times 356\,460)^2} \\ &= \sqrt{(78\,750 + 51\,850)^2 + (356\,460)^2} = 380 \times 10^3 \text{ N-m} \end{aligned}$$

We also know that the equivalent twisting moment for a hollow shaft (T_e),

$$380 \times 10^3 = \frac{\pi}{16} \times \tau (d_o)^3 (1 - k^4) = \frac{\pi}{16} \times \tau (0.5)^3 [1 - (0.6)^4] = 0.02 \tau$$

$\therefore \tau = 380 \times 10^3 / 0.02 = 19 \times 10^6 \text{ N/m}^2 = 19 \text{ MPa Ans.}$

2. Angular twist between the bearings

Let θ = Angular twist between the bearings in radians.

We know that the polar moment of inertia for a hollow shaft,

$$J = \frac{\pi}{32} [(d_o)^4 - (d_i)^4] = \frac{\pi}{32} [(0.5)^4 - (0.3)^4] = 0.00534 \text{ m}^4$$

From the torsion equation,

$$\frac{T}{J} = \frac{G \times \theta}{L}, \text{ we have}$$

$$\theta = \frac{T \times L}{G \times J} = \frac{356460 \times 6}{84 \times 10^9 \times 0.00534} = 0.0048 \text{ rad}$$

... (Taking $G = 84 \text{ GPa} = 84 \times 10^9 \text{ N/m}^2$)

$$= 0.0048 \times \frac{180}{\pi} = 0.275^\circ \text{ Ans.}$$

Design of Shafts on the basis of Rigidity:

Sometimes the shafts are to be designed on the basis of rigidity. We shall consider the following two types of rigidity.

1. Torsional rigidity. The torsional rigidity is important in the case of camshaft of an I.C. engine where the timing of the valves would be affected. The permissible amount of twist should not exceed 0.25° per metre length of such shafts. For line shafts or transmission shafts, deflections 2.5 to 3 degree per metre length may be used as limiting value. The widely used deflection for the shafts is limited to 1 degree in a length equal to twenty times the diameter of the shaft. The torsional deflection may be obtained by using the torsion equation,

$$\frac{T}{J} = \frac{G \cdot \theta}{L} \quad \text{or} \quad \theta = \frac{T \cdot L}{J \cdot G}$$

where

θ = Torsional deflection or angle of twist in radians,

T = Twisting moment or torque on the shaft,

J = Polar moment of inertia of the cross-sectional area about the axis of rotation,

G = Modulus of rigidity for the shaft material, and

L = Length of the shaft.

2. Lateral rigidity. It is important in case of transmission shafting and shafts running at high speed, where small lateral deflection would cause huge out-of-balance forces.

The lateral rigidity is also important for maintaining proper bearing clearances and for correct gear teeth alignment. If the shaft is of uniform cross-section, then the lateral deflection of a shaft may be obtained by using the deflection formulae as in Strength of Materials. But when the shaft is of variable cross-section, then the lateral deflection may be determined from the fundamental equation for the elastic curve of a beam, *i.e.*

$$\frac{d^2 y}{dx^2} = \frac{M}{EI}$$

A steel spindle transmits 4 kW at 800 r.p.m. The angular deflection should not exceed 0.25° per metre of the spindle. If the modulus of rigidity for the material of the spindle is 84 GPa, find the diameter of the spindle and the shear stress induced in the spindle.

Solution. Given : $P = 4 \text{ kW} = 4000 \text{ W}$; $N = 800 \text{ r.p.m.}$; $\theta = 0.25^\circ = 0.25 \times \frac{\pi}{180} = 0.0044 \text{ rad}$;
 $L = 1 \text{ m} = 1000 \text{ mm}$; $G = 84 \text{ GPa} = 84 \times 10^9 \text{ N/m}^2 = 84 \times 10^3 \text{ N/mm}^2$

Diameter of the spindle

Let $d = \text{Diameter of the spindle in mm.}$

We know that the torque transmitted by the spindle,

$$T = \frac{P \times 60}{2\pi N} = \frac{4000 \times 60}{2\pi \times 800} = 47.74 \text{ N-m} = 47\,740 \text{ N-mm}$$

We also know that $\frac{T}{J} = \frac{G \times \theta}{L}$ or $J = \frac{T \times l}{G \times \theta}$

or $\frac{\pi}{32} \times d^4 = \frac{47\,740 \times 1000}{84 \times 10^3 \times 0.0044} = 129\,167$

$\therefore d^4 = 129\,167 \times 32 / \pi = 1.3 \times 10^6$ or $d = 33.87$ say 35 mm Ans.

Shear stress induced in the spindle

Let $\tau = \text{Shear stress induced in the spindle.}$

We know that the torque transmitted by the spindle (T),

$$47\,740 = \frac{\pi}{16} \times \tau \times d^3 = \frac{\pi}{16} \times \tau (35)^3 = 8420 \tau$$

$\therefore \tau = 47\,740 / 8420 = 5.67 \text{ N/mm}^2 = 5.67 \text{ MPa Ans.}$

Compare the weight, strength and stiffness of a hollow shaft of the same external diameter as that of solid shaft. The inside diameter of the hollow shaft being half the external diameter. Both the shafts have the same material and length.

Solution. Given : $d_o = d$; $d_i = d_o / 2$ or $k = d_i / d_o = 1 / 2 = 0.5$

Comparison of weight

We know that weight of a hollow shaft,

$$\begin{aligned} W_H &= \text{Cross-sectional area} \times \text{Length} \times \text{Density} \\ &= \frac{\pi}{4} [(d_o)^2 - (d_i)^2] \times \text{Length} \times \text{Density} \end{aligned} \quad \dots(i)$$

and weight of the solid shaft,

$$W_S = \frac{\pi}{4} \times d^2 \times \text{Length} \times \text{Density} \quad \dots(ii)$$

Since both the shafts have the same material and length, therefore by dividing equation (i) by equation (ii), we get

$$\begin{aligned} \frac{W_H}{W_S} &= \frac{(d_o)^2 - (d_i)^2}{d^2} = \frac{(d_o)^2 - (d_i)^2}{(d_o)^2} \quad \dots(\because d = d_o) \\ &= 1 - \frac{(d_i)^2}{(d_o)^2} = 1 - k^2 = 1 - (0.5)^2 = 0.75 \text{ Ans.} \end{aligned}$$

Comparison of strength

We know that strength of the hollow shaft,

$$T_H = \frac{\pi}{16} \times \tau (d_o)^3 (1 - k^4) \quad \dots(iii)$$

and strength of the solid shaft,

$$T_S = \frac{\pi}{16} \times \tau \times d^3 \quad \dots(iv)$$

Dividing equation (iii) by equation (iv), we get

$$\begin{aligned} \frac{T_H}{T_S} &= \frac{(d_o)^3 (1 - k^4)}{d^3} = \frac{(d_o)^3 (1 - k^4)}{(d_o)^3} = 1 - k^4 \quad \dots(\because d = d_o) \\ &= 1 - (0.5)^4 = 0.9375 \text{ Ans.} \end{aligned}$$

Comparison of stiffness

We know that stiffness

$$= \frac{T}{\theta} = \frac{G \times J}{L}$$

\therefore Stiffness of a hollow shaft,

$$S_H = \frac{G}{L} \times \frac{\pi}{32} [(d_o)^4 - (d_i)^4] \quad \dots(v)$$

and stiffness of a solid shaft,

$$S_S = \frac{G}{L} \times \frac{\pi}{32} \times d^4 \quad \dots(vi)$$

Dividing equation (v) by equation (vi), we get

$$\begin{aligned} \frac{S_H}{S_S} &= \frac{(d_o)^4 - (d_i)^4}{d^4} = \frac{(d_o)^4 - (d_i)^4}{(d_o)^4} = 1 - \frac{(d_i)^4}{(d_o)^4} \quad \dots(\because d = d_o) \\ &= 1 - k^4 = 1 - (0.5)^4 = 0.9375 \text{ Ans.} \end{aligned}$$

Design of keys:

A key is a piece of mild steel inserted between the shaft and hub or boss of the pulley to connect these together in order to prevent relative motion between them. It is always inserted parallel to the axis of the shaft. Keys are used as temporary fastenings and are subjected to considerable crushing and shearing stresses. A keyway is a slot or recess in a shaft and hub of the pulley to accommodate a key.

Types of Keys

The following types of keys are important from the subject point of view :

1. Sunk keys,
2. Saddle keys,
3. Tangent keys,
4. Round keys, and
5. Splines.

Sunk Keys:

The sunk keys are provided half in the keyway of the shaft and half in the keyway of the hub or boss of the pulley. The sunk keys are of the following types :

1. Rectangular sunk key.

A rectangular sunk key is shown in Fig. The usual proportions of this key are :

Width of key, $w = d / 4$; and

thickness of key, $t = 2w / 3 = d / 6$

where d = Diameter of the shaft or diameter of the hole in the hub.

The key has taper 1 in 100 on the top side only.

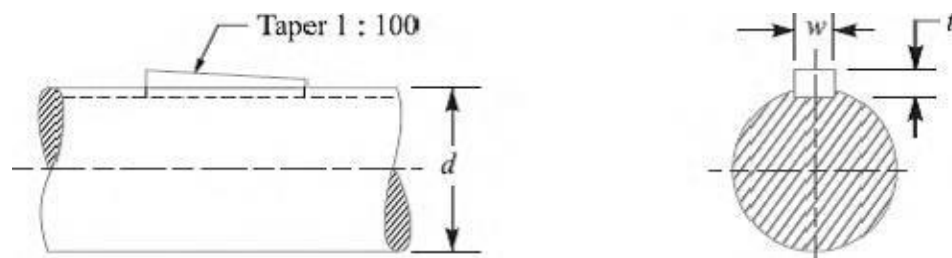

Fig. Sunk Key

2. **Square sunk key.** The only difference between a rectangular sunk key and a square sunk

key is that its width and thickness are equal, i.e. $w = t = d / 4$

3. Parallel sunk key. The parallel sunk keys may be of rectangular or square section uniform in width and thickness throughout. It may be noted that a parallel key is a taper less and is used where the pulley, gear or other mating piece is required to slide along the shaft.

4. Gib-head key. It is a rectangular sunk key with a head at one end known as **gib head**. It is usually provided to facilitate the removal of key. A gib head key is shown in Fig.

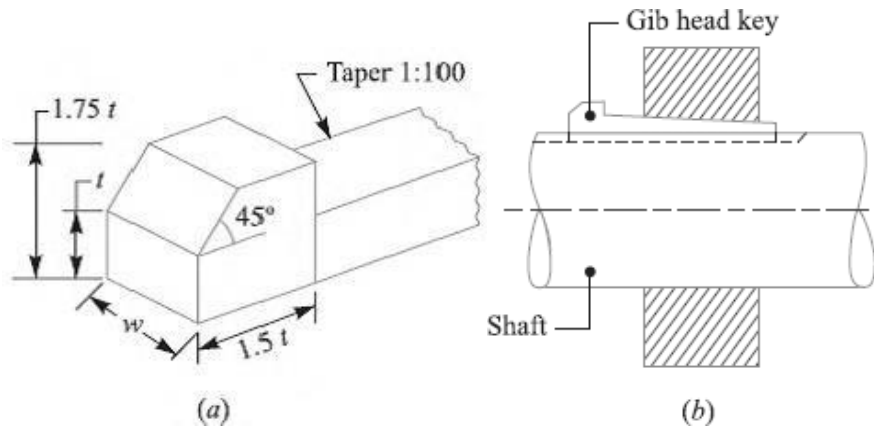

Fig. Gib head key and its use

The usual proportions of the gib head key are:

Width, $w = d / 4$; and

thickness at large end, $t = 2w / 3 = d / 6$.

5. Feather key. A key attached to one member of a pair and which permits relative axial movement is known as **feather key**. It is a special type of parallel key which transmits a turning moment and also permits axial movement. It is fastened either to the shaft or hub, the key being a sliding fit in the key way of the moving piece.

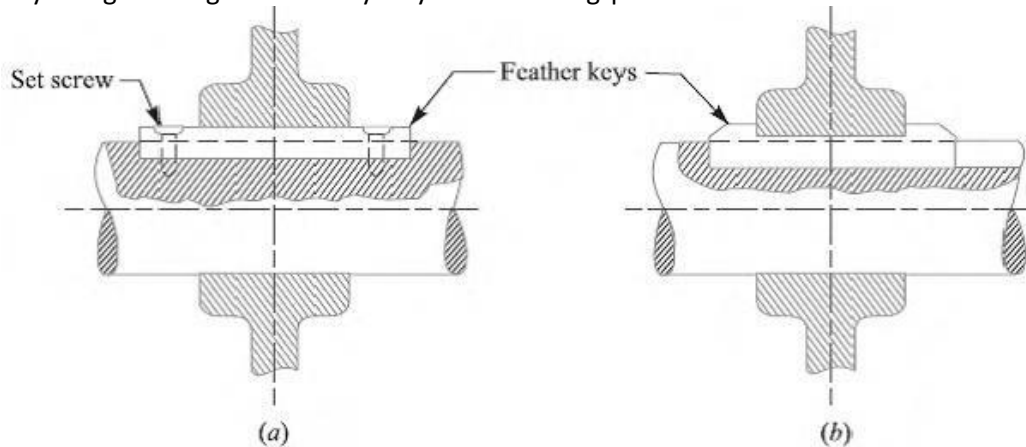

Fig. Feather Keys

6. Woodruff key.

The woodruff key is an easily adjustable key. It is a piece from a cylindrical disc having segmental cross-section. A woodruff key is capable of tilting in a recess milled out in the shaft by a cutter having the same curvature as the disc from which the key is made. This key is largely used in machine tool and automobile construction.

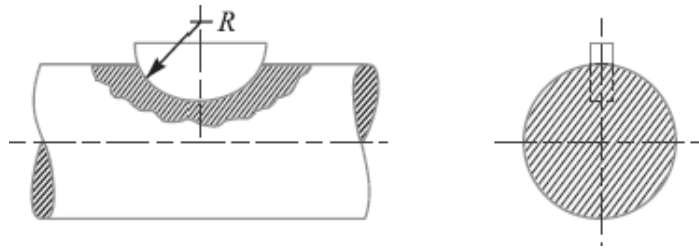

Fig. Woodruff Key

The main advantages of a woodruff key are as follows:

1. It accommodates itself to any taper in the hub or boss of the mating piece.
2. It is useful on tapering shaft ends. Its extra depth in the shaft prevents any tendency to turn over in its keyway.

The disadvantages are:

1. The depth of the keyway weakens the shaft
2. It can not be used as a feather.

Saddle keys:

A saddle keys are of the following types

- 1.flat saddle key
2. hollow saddle key

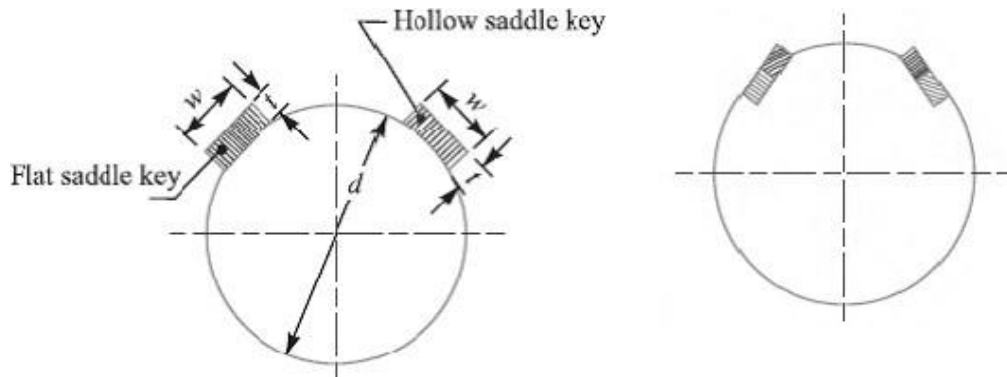

A **flat saddle key** is a type of key which fits in the hub and is flat on the shaft as shown in fig. It is likely to slip round the shaft under load. Therefore it is used for comparatively light loads.

A **hollow saddle key** is a taper key which fits in a keyway in the hub and the bottom of the key is shaped to fit the curved surface of the shaft. Since hollow saddle keys hold on by friction, therefore these are suitable for light loads. It is usually used as a temporary fastening in fixing and setting eccentrics, cams etc.

Tangent Keys

The tangent keys are fitted in pair at right angles as shown in Fig. Each key is to withstand torsion in one direction only. These are used in large heavy duty shafts.

Round Keys

The round keys, as shown in Fig. (a) are circular in section and fit into holes drilled partly in the shaft and partly in the hub. They have the advantage that their keyways may be drilled and reamed after the mating parts have been assembled. Round keys are usually considered to be most appropriate for low power drives.

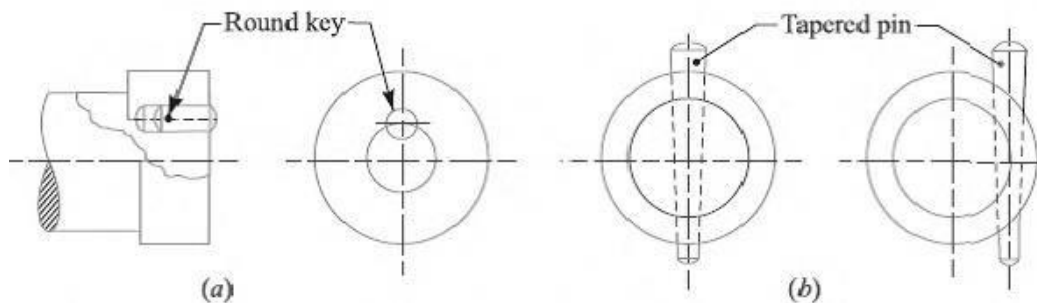

Stresses in Keys:

Forces acting on a Sunk Key

When a key is used in transmitting torque from a shaft to a rotor or hub, the following two types of forces act on the key:

1. Forces (F_1) due to fit of the key in its keyway, as in a tight fitting straight key or in a tapered key driven in place. These forces produce compressive stresses in the key which are difficult to determine in magnitude.
2. Forces (F) due to the torque transmitted by the shaft. These forces produce shearing and compressive (or crushing) stresses in the key.

The forces acting on a key for a clockwise torque being transmitted from a shaft to a hub are shown in Fig.

In designing a key, forces due to fit of the key are neglected and it is assumed that the distribution of forces along the length of key is uniform.

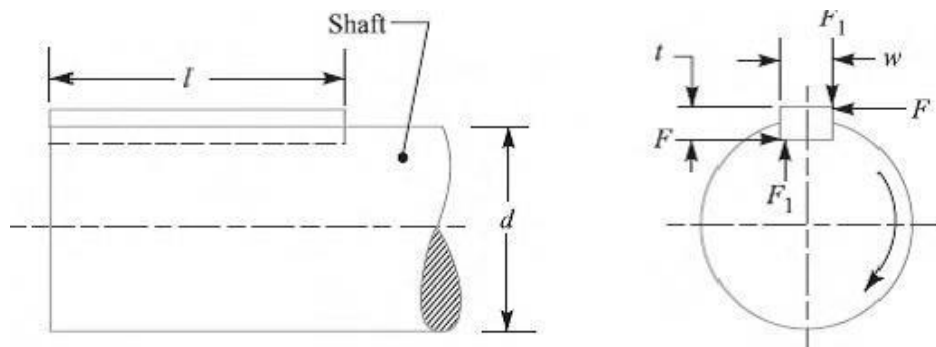

Strength of a Sunk Key

A key connecting the shaft and hub is shown in Fig.

Let

T = Torque transmitted by the shaft,

F = Tangential force acting at the circumference of the shaft,

d = Diameter of shaft,

l = Length of key,

w = Width of key.

t = Thickness of key, and

τ and σ_c = Shear and crushing stresses for the material of key.

A little consideration will show that due to the power transmitted by the shaft, the key may fail due to shearing or crushing. Considering shearing of the key, the tangential shearing force acting at the circumference of the shaft,

$$F = \text{Area resisting shearing} \times \text{Shear stress} = l \times w \times \tau$$

Therefore, Torque transmitted by the shaft,

$$T = F \times \frac{d}{2} = l \times w \times \tau \times \frac{d}{2} \quad \dots(i)$$

Considering crushing of the key, the tangential crushing force acting at the circumference of the shaft,

$$F = \text{Area resisting crushing} \times \text{Crushing stress}$$

$$= l \times \frac{t}{2} \times \sigma_c$$

Therefore, Torque transmitted by the shaft,

$$T = F \times \frac{d}{2} = l \times \frac{t}{2} \times \sigma_c \times \frac{d}{2} \quad \dots(ii)$$

The key is equally strong in shearing and crushing, if

$$l \times w \times \tau \times \frac{d}{2} = l \times \frac{t}{2} \times \sigma_c \times \frac{d}{2}$$

Or

$$\frac{w}{t} = \frac{\sigma_c}{2\tau}$$

The permissible crushing stress for the usual key material is at least twice the permissible shearing stress. Therefore from the above equation, we have $w = t$. In other words, a square key is equally strong in shearing and crushing.

In order to find the length of the key to transmit full power of the shaft, the shearing strength of the key is equal to the torsional shear strength of the shaft. We know that the shearing strength of key,

$$T = l \times w \times \tau \times \frac{d}{2}$$

And torsional shear strength of the shaft,

$$T = \frac{\pi}{16} \times \tau_1 \times d^3$$

From the above

$$l \times w \times \tau \times \frac{d}{2} = \frac{\pi}{16} \times \tau_1 \times d^3$$
$$l = \frac{\pi}{8} \times \frac{\tau_1 d^2}{w \times \tau} = \frac{\pi d}{2} \times \frac{\tau_1}{\tau} = 1.571 d \times \frac{\tau_1}{\tau}$$

When the key material is same as that of the shaft, then $\tau = \tau_1$. So, $l = 1.571 d$.

Chapter-4

DESIGN OF COUPLING

Shaft Coupling

Shafts are usually available up to 7 meters length due to inconvenience in transport. In order to have a greater length, it becomes necessary to join two or more pieces of the shaft by means of a coupling.

Shaft couplings are used in machinery for several purposes, the most common of which are the following:

1. To provide for the connection of shafts of units those are manufactured separately such as a motor and generator and to provide for disconnection for repairs or alternations.
2. To provide for misalignment of the shafts or to introduce mechanical flexibility.
3. To reduce the transmission of shock loads from one shaft to another.
4. To introduce protection against overloads.
5. It should have no projecting parts.

Types of Shafts Couplings

Shaft couplings are divided into two main groups as follows:

1. Rigid coupling. It is used to connect two shafts which are perfectly aligned. Following types of rigid coupling are important from the subject point of view:

- (a) Sleeve or muff coupling.
- (b) Clamp or split-muff or compression coupling, and
- (c) Flange coupling.

2. Flexible coupling. It is used to connect two shafts having both lateral and angular misalignment.

Following types of flexible coupling are important from the subject point of view:

- (a) Bushed pin type coupling,
- (b) Universal coupling, and
- (c) Oldham coupling.

Sleeve or Muff-coupling

It is the simplest type of rigid coupling, made of cast iron. It consists of a hollow cylinder whose inner diameter is the same as that of the shaft. It is fitted over the ends of the two shafts by means of a gib head key, as shown in Fig. The power is transmitted from one shaft to the other shaft by means of a key and a sleeve. It is, therefore, necessary that all the elements must be strong enough to transmit the torque. The usual proportions of a cast iron sleeve coupling are as follows:

Outer diameter of the sleeve, $D = 2d + 13 \text{ mm}$

And length of the sleeve,

$$L = 3.5 d$$

Where, d = diameter of the shaft.

In designing a sleeve or muff-coupling, the following procedure may be adopted.

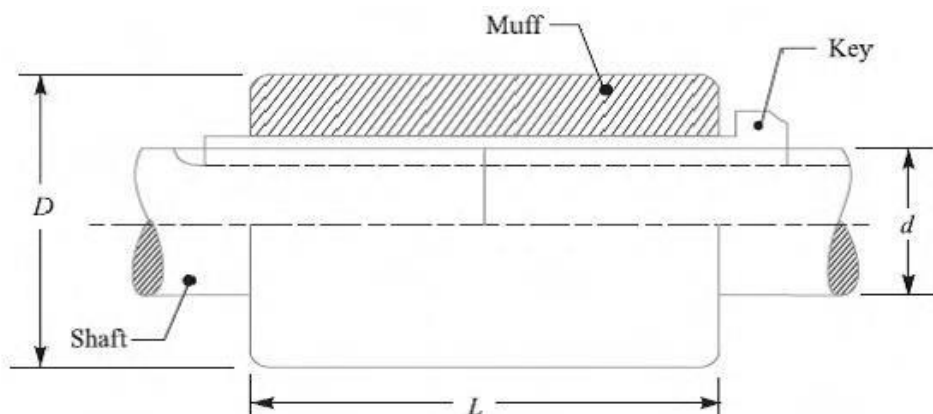

1. Design for sleeve

The sleeve is designed by considering it as a hollow shaft

Let T = Torque to be transmitted by the coupling,
and

τ_c = Permissible shear stress for the material of the sleeve which is cast iron.

The safe value of shear stress for cast iron may be taken as 14 MPa.

We know that torque transmitted by a hollow section,

$$T = \frac{\pi}{16} \times \tau_c \left(\frac{D^4 - d^4}{D} \right) = \frac{\pi}{16} \times \tau_c \times D^3 (1 - k^4) \quad \dots (\because k = d/D)$$

From this expression, the induced shear stress in the sleeve may be checked.

2. Design for key

The key for the coupling may be designed in the similar way as discussed in Unit-5. The width and thickness of the coupling key is obtained from the proportions. The length of the coupling key is at least equal to the length of the sleeve (i.e. 3.5 d). The coupling key is usually made into two parts so that the length of the key in each shaft,

$$l = \frac{L}{2} = \frac{3.5 d}{2}$$

After fixing the length of key in each shaft, the induced shearing and crushing stresses may be checked. We know that torque transmitted,

$$T = l \times w \times \tau \times \frac{d}{2} \quad \dots \text{(Considering shearing of the key)}$$

$$= l \times \frac{t}{2} \times \sigma_c \times \frac{d}{2} \quad \dots \text{(Considering crushing of the key)}$$

Note: The depth of the keyway in each of the shafts to be connected should be exactly the same and the diameters should also be same. If these conditions are not satisfied, then the key will be bedded on one shaft while in the other it will be loose. In order to prevent this, the key is made in two parts which may be driven from the same end for each shaft or they may be driven from opposite ends.

Design and make a neat dimensioned sketch of a muff coupling which is used to connect two steel shafts transmitting 40 kW at 350 r.p.m. The material for the shafts and key is plain carbon steel for which allowable shear and crushing stresses may be taken as 40 MPa and 80 MPa respectively. The material for the muff is cast iron for which the allowable shear stress may be assumed as 15 MPa.

Solution:

Given: $P = 40 \text{ kW} = 40 \times 10^3 \text{ W}$; $N = 350 \text{ r.p.m.}$; $\tau_s = 40 \text{ MPa} = 40 \text{ N/mm}^2$; $\sigma_{cs} = 80 \text{ MPa} = 80 \text{ N/mm}^2$; $\sigma_c = 15 \text{ MPa} = 15 \text{ N/mm}^2$.

$$T = \frac{P \times 60}{2 \pi N} = \frac{40 \times 10^3 \times 60}{2 \pi \times 350} = 1100 \text{ N-m}$$

$$= 1100 \times 10^3 \text{ N-mm}$$

We also know that the torque transmitted (T),

$$1100 \times 10^3 = \frac{\pi}{16} \times \tau_s \times d^3 = \frac{\pi}{16} \times 40 \times d^3 = 7.86 d^3$$

$$\therefore d^3 = 1100 \times 10^3 / 7.86 = 140 \times 10^3 \text{ or } d = 52 \text{ say } 55 \text{ mm Ans.}$$

2. Design for sleeve

We know that outer diameter of the muff,

$$D = 2d + 13 \text{ mm} = 2 \times 55 + 13 = 123 \text{ say } 125 \text{ mm Ans.}$$

and length of the muff,

$$L = 3.5 d = 3.5 \times 55 = 192.5 \text{ say } 195 \text{ mm Ans.}$$

Let us now check the induced shear stress in the muff. Let τ_c be the induced shear stress in the muff which is made of cast iron. Since the muff is considered to be a hollow shaft, therefore the torque transmitted (T),

$$1100 \times 10^3 = \frac{\pi}{16} \times \tau_c \left(\frac{D^4 - d^4}{D} \right) = \frac{\pi}{16} \times \tau_c \left[\frac{(125)^4 - (55)^4}{125} \right]$$

$$= 370 \times 10^3 \tau_c$$

$$\therefore \tau_c = 1100 \times 10^3 / 370 \times 10^3 = 2.97 \text{ N/mm}^2$$

Since the induced shear stress in the muff (cast iron) is less than the permissible shear stress of 15 N/mm², therefore the design of muff is safe.

3. Design for key

From Design data Book, we find that for a shaft of 55 mm diameter,

$$\text{Width of key, } w = 18 \text{ mm Ans.}$$

Since the crushing stress for the key material is twice the shearing stress, therefore a square key may be used.

$$\text{Then, Thickness of key, } t = w = 18 \text{ mm Ans.}$$

We know that length of key in each shaft,

$$l = L / 2 = 195 / 2 = 97.5 \text{ mm Ans.}$$

Let us now check the induced shear and crushing stresses in the key. First of all, let us consider shearing of the key.

We know that torque transmitted (T),

$$1100 \times 10^3 = l \times w \times \tau_s \times \frac{d}{2} = 97.5 \times 18 \times \tau_s \times \frac{55}{2} = 48.2 \times 10^3 \tau_s$$

$$\tau_s = 1100 \times 10^3 / 48.2 \times 10^3 = 22.8 \text{ N/mm}^2$$

Now considering crushing of the key. We know that torque transmitted (T),

$$1100 \times 10^3 = l \times \frac{t}{2} \times \sigma_{cs} \times \frac{d}{2} = 97.5 \times \frac{18}{2} \times \sigma_{cs} \times \frac{55}{2} = 24.1 \times 10^3 \sigma_{cs}$$

$$\sigma_{cs} = 1100 \times 10^3 / 24.1 \times 10^3 = 45.6 \text{ N/mm}^2$$

Since the induced shear and crushing stresses are less than the permissible stresses, therefore the design of key is safe.

Clamp or Compression Coupling or split muff coupling

It is also known as **split muff coupling**. In this case, the muff or sleeve is made into two halves and are bolted together as shown in Fig. The halves of the muff are made of cast iron.

The shaft ends are made to a butt each other and a single key is fitted directly in the keyways of both the shafts. One-half of the muff is fixed from below and the other half is placed from above. Both the halves are held together by means of mild steel studs or bolts and nuts. The number of bolts may be two, four or six. The nuts are recessed into the bodies of the muff castings.

This coupling may be used for heavy duty and moderate speeds. The advantage of this coupling is that the position of the shafts need not be changed for assembling or disassembling of the coupling.

The usual proportions of the muff for the clamp or compression coupling are:

Diameter of the muff or sleeve, $D = 2d + 13 \text{ mm}$

Length of the muff or sleeve, $L = 3.5 d$

Where d = Diameter of the shaft.

In the clamp or compression coupling, the power is transmitted from one shaft to the other by means of key and the friction between the muff and shaft. In designing this type of coupling, the following procedure may be adopted.

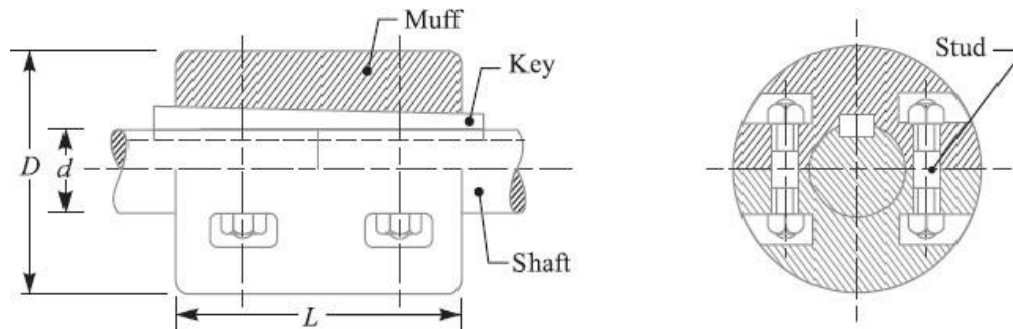

1. Design of muff and key

The muff and key are designed in the similar way as discussed in muff coupling.

2. Design of clamping bolts

Let T = Torque transmitted by the shaft,

d = Diameter of shaft,

d_b = Root or effective diameter of bolt,

n = Number of bolts,

σ_t = Permissible tensile stress for bolt material,

μ = Coefficient of friction between the muff and shaft, and

L = Length of muff.

We know that the force exerted by each bolt

$$= \frac{\pi}{4} (d_b)^2 \sigma_t$$

Then, Force exerted by the bolts on each side of the shaft

$$= \frac{\pi}{4} (d_b)^2 \sigma_t \times \frac{n}{2}$$

Let p be the pressure on the shaft and the muff surface due to the force, then for uniform pressure distribution over the surface,

$$p = \frac{\text{Force}}{\text{Projected area}} = \frac{\frac{\pi}{4} (d_b)^2 \sigma_t \times \frac{n}{2}}{\frac{1}{2} L \times d}$$

Then, Frictional force between each shaft and muff,

$$\begin{aligned} F &= \mu \times \text{pressure} \times \text{area} = \mu \times p \times \frac{1}{2} \times \pi d \times L \\ &= \mu \times \frac{\frac{\pi}{4} (d_b)^2 \sigma_t \times \frac{n}{2}}{\frac{1}{2} L \times d} \times \frac{1}{2} \pi d \times L \end{aligned}$$

$$= \mu \times \frac{\pi}{4} (d_b)^2 \sigma_t \times \frac{n}{2} \times \pi = \mu \times \frac{\pi^2}{8} (d_b)^2 \sigma_t \times n$$

$$T = F \times \frac{d}{2} = \mu \times \frac{\pi^2}{8} (d_b)^2 \sigma_t \times n \times \frac{d}{2} = \frac{\pi^2}{16} \times \mu (d_b)^2 \sigma_t \times n \times d$$

And the torque that can be transmitted by the coupling,

From this relation, the root diameter of the bolt (d_b) may be evaluated.

Flange Coupling

A flange coupling usually applies to a coupling having two separate cast iron flanges. Each flange is mounted on the shaft end and keyed to it. The faces are turned up at right angle to the axis of the shaft. One of the flanges has a projected portion and the other flange has a corresponding recess. This helps to bring the shafts into line and to maintain alignment. The two flanges are coupled together by means of bolts and nuts. The flange coupling is adapted to heavy loads and hence it is used on largeshafting.

The flange couplings are of the following three types:

1. Unprotected type flange coupling. In an unprotected type flange coupling, as shown in Fig.1, each shaft is keyed to the boss of a flange with a counter sunk key and the flanges are coupled together by means of bolts. Generally, three, four or six bolts are used. The keys are staggered at right angle along the circumference of the shafts in order to divide the weakening effect caused by keyways.

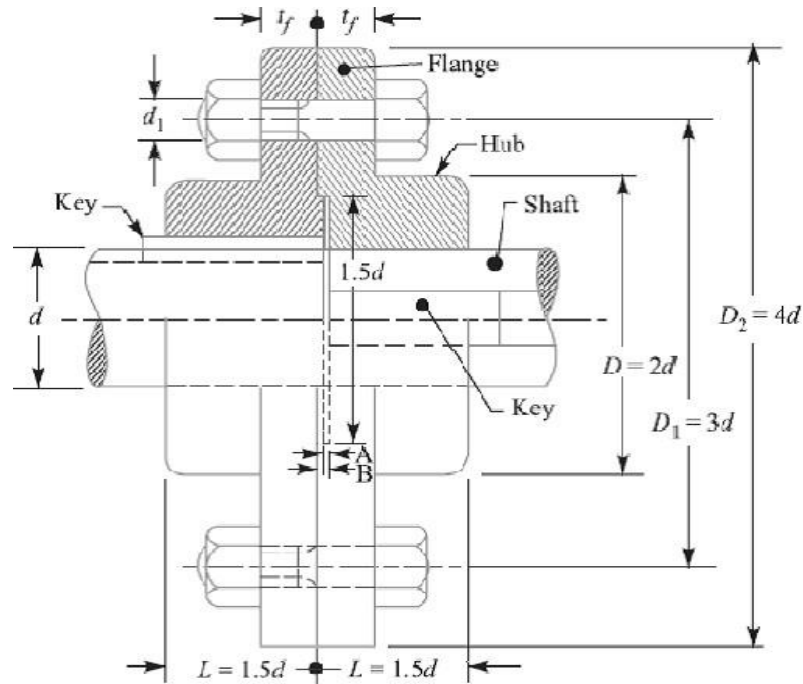

Fig.1 Unprotected Type Flange Coupling.

The usual proportions for an unprotected type cast iron flange couplings, as shown in Fig.1, are as follows:

If d is the diameter of the shaft or inner diameter of the hub, then

Outside diameter of hub, $D = 2d$

Length of hub, $L = 1.5d$

Pitch circle diameter of bolts, $D_1 = 3d$

Outside diameter of flange,

$$D_2 = D_1 + (D_1 - D) = 2D_1 - D = 4d$$

Thickness of flange, $t_f = 0.5d$

Number of bolt = 3, for d upto 40 mm

= 4, for d upto 100 mm

= 6, for d upto 180 mm

2. Protected type flange coupling. In a protected type flange coupling, as shown in Fig.2, the protruding bolts and nuts are protected by flanges on the two halves of the coupling, in order to avoid danger to the workman. The thickness of the protective circumferential flange (t_p) is taken as $0.25 d$. The other proportions of the coupling are same as for unprotected type flange coupling.

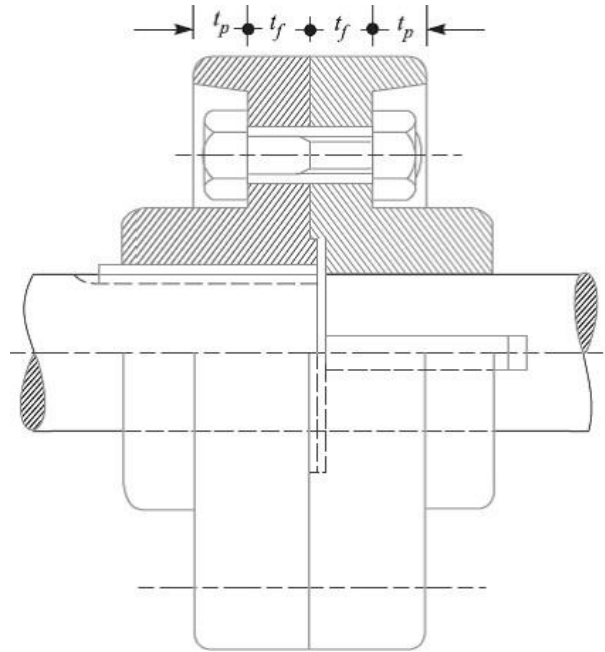

Fig.2. Protected Type Flange Coupling.

3. Marine type flange coupling. In a marine type flange coupling, the flanges are forged integral with the shafts as shown in Fig.3.

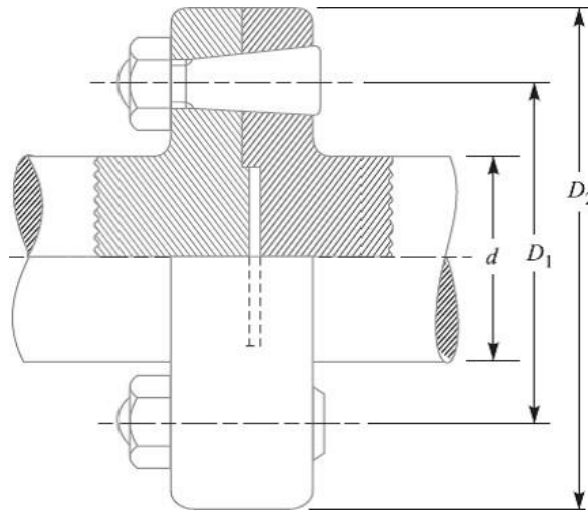

Fig.3. Solid Flange Coupling or Marine Type flange coupling.

The flanges are held together by means of tapered headless bolts, numbering from four to twelve depending upon the diameter of shaft. The other proportions for the marine type flange coupling are taken as follows:

- Thickness of flange = $d / 3$
- Taper of bolt = 1 in 20 to 1 in 40
- Pitch circle diameter of bolts, $D_1 = 1.6d$
- Outside diameter of flange, $D_2 = 2.2d$

Design of Flange Coupling

Let d = Diameter of shaft or inner diameter of hub,

- D = Outer diameter of hub,
- D_1 = Nominal or outside diameter of bolt, D_1 = Diameter of bolt circle,
- n = Number of bolts,
- t_f = Thickness of flange,
- τ_s, τ_b and τ_k = Allowable shear stress for shaft, bolt and key material respectively
- τ_c = Allowable shear stress for the flange material i.e. cast iron,
- σ_{cb} , and σ_{ck} = Allowable crushing stress for bolt and key material respectively.

The flange coupling is designed as discussed below:

1. Design for hub

The hub is designed by considering it as a hollow shaft, transmitting the same torque (T) as that of a solid shaft.

The outer diameter of hub is usually taken as twice the diameter of shaft. Therefore

$$T = \frac{\pi}{16} \times \tau_c \left(\frac{D^4 - d^4}{D} \right)$$

from the above relation, the induced shearing stress in the hub may be checked.

The length of hub (L) is taken as $1.5d$.

2. Design for key

The key is designed with usual proportions and then checked for shearing and crushing stresses. The material of key is usually the same as that of shaft. The length of key is taken equal to the length of hub.

3. Design for flange

The flange at the junction of the hub is under shear while transmitting the torque. Therefore, the torque transmitted,

T = Circumference of hub \times Thickness of flange \times Shear stress of flange \times Radius of hub

$$= \pi D \times t_f \times \tau_c \times \frac{D}{2} = \frac{\pi D^2}{2} \times \tau_c \times t_f$$

The thickness of flange is usually taken as half the diameter of shaft. Therefore from the above relation, the induced shearing stress in the flange may be checked.

4. Design for bolts

The bolts are subjected to shear stress due to the torque transmitted. The number of bolts (n) depends upon the diameter of shaft and the pitch circle diameter of bolts (D_1) is taken as $3d$. We know that

Load on each bolt

$$= \frac{\pi}{4} (d_1)^2 \tau_b$$

Then, Total load on all the bolts

$$= \frac{\pi}{4} (d_1)^2 \tau_b \times n$$

And torque transmitted,

$$T = \frac{\pi}{4} (d_1)^2 \tau_b \times n \times \frac{D_1}{2}$$

From this equation, the diameter of bolt (d_1) may be obtained. Now the diameter of bolt may be checked in crushing.

We know that area resisting crushing of all the bolts

$= n \times d_1 \times t_f$ And crushing strength of all the bolts $= (n \times d_1 \times t_f) \sigma_{cb}$

Torque,

$$T = (n \times d_1 \times t_f \times \sigma_{cb}) \frac{D_1}{2}$$

From this equation, the induced crushing stress in the bolts may be checked.

Design a cast iron protective type flange coupling to transmit 15 kW at 900 r.p.m. from an electric motor to a compressor. The service factor may be assumed as 1.35. The following permissible stresses may be used :

Shear stress for shaft, bolt and key material = 40 MPa

Crushing stress for bolt and key = 80 MPa

Shear stress for cast iron = 8 MPa

Solution. Given: $P = 15 \text{ kW} = 15 \times 10^3 \text{ W}$; $N = 900 \text{ r.p.m.}$; Service factor = 1.35 ; $\tau_s = \tau_b = \tau_k = 40 \text{ MPa} = 40 \text{ N/mm}^2$; $\sigma_{cb} = \sigma_{ck} = 80 \text{ MPa} = 80 \text{ N/mm}^2$; $\tau_c = 8 \text{ MPa} = 8 \text{ N/mm}^2$. The protective type flange coupling is designed as discussed below:

1. Design for hub

First of all, let us find the diameter of the shaft (d). We know that the torque transmitted by the shaft,

$$T = \frac{P \times 60}{2 \pi N} = \frac{15 \times 10^3 \times 60}{2 \pi \times 900} = 159.13 \text{ N-m}$$

Since the service factor is 1.35, therefore the maximum torque transmitted by the shaft, $T_{\max} = 1.35 \times 159.13 = 215 \text{ N-m} = 215 \times 10^3 \text{ N-mm}$

We know that the torque transmitted by the shaft (T),

$$215 \times 10^3 = \frac{\pi}{16} \times \tau_s \times d^3 = \frac{\pi}{16} \times 40 \times d^3 = 7.86 d^3$$

$$d^3 = 215 \times 10^3 / 7.86 = 27.4 \times 10^3 \quad \text{or} \quad d = 30.1 \text{ say } 35 \text{ mm Ans.}$$

We know that outer diameter of the hub,

$$D = 2d = 2 \times 35 = 70 \text{ mm Ans.}$$

And length of hub, $L = 1.5 d = 1.5 \times 35 = 52.5 \text{ mm Ans.}$

Let us now check the induced shear stress for the hub material which is cast iron. Considering the hub as a hollow shaft. We know that the maximum torque transmitted (T_{\max}).

$$215 \times 10^3 = \frac{\pi}{16} \times \tau_c \left[\frac{D^4 - d^4}{D} \right] = \frac{\pi}{16} \times \tau_c \left[\frac{(70)^4 - (35)^4}{70} \right] = 63\,147 \tau_c$$

$$\text{Then, } \tau_c = 215 \times 10^3 / 63\,147 = 3.4 \text{ N/mm}^2 = 3.4 \text{ MPa}$$

Since the induced shear stress for the hub material (i.e. cast iron) is less than the permissible value of 8 MPa, therefore the design of hub is safe.

Design for key

Since the crushing stress for the key material is twice its shear stress (i.e. $\sigma_{ck} = 2\tau_k$), therefore a square key may be used. From DDB, we find that for a shaft of 35 mm diameter,

$$\text{Width of key, } w = 12 \text{ mm Ans.}$$

$$\text{And thickness of key, } t = w = 12 \text{ mm Ans.}$$

The length of key (l) is taken equal to the length of hub. Then, $l = L = 52.5 \text{ mm Ans.}$

Let us now check the induced stresses in the key by considering it in shearing and crushing. Considering the key in shearing. We know that the maximum torque transmitted (T_{\max}),

$$215 \times 10^3 = l \times w \times \tau_k \times \frac{d}{2} = 52.5 \times 12 \times \tau_k \times \frac{35}{2} = 11\,025 \tau_k$$

$$\text{Then, } \tau_k = 215 \times 10^3 / 11\,025 = 19.5 \text{ N/mm}^2 = 19.5 \text{ MPa}$$

Considering the key in crushing. We know that the maximum torque transmitted (T_{\max}),

$$215 \times 10^3 = l \times \frac{t}{2} \times \sigma_{ck} \times \frac{d}{2} = 52.5 \times \frac{12}{2} \times \sigma_{ck} \times \frac{35}{2} = 5512.5 \sigma_{ck}$$

$$\sigma_{ck} = 215 \times 10^3 / 5512.5 = 39 \text{ N/mm}^2 = 39 \text{ MPa.}$$

Since the induced shear and crushing stresses in the key are less than the permissible stresses, therefore the design for key is safe.

2. Design for flange

The thickness of flange (t_f) is taken as 0.5 d.

$$\text{Then, } t_f = 0.5 d = 0.5 \times 35 = 17.5 \text{ mm Ans.}$$

Let us now check the induced shearing stress in the flange by considering the flange at the junction of the hub in shear.

We know that the maximum torque transmitted (T_{\max}),

$$215 \times 10^3 = \frac{\pi D^2}{2} \times \tau_c \times t_f = \frac{\pi(70)^2}{2} \times \tau_c \times 17.5 = 134\,713 \tau_c$$

$$\tau_c = 215 \times 10^3 / 134\,713 = 1.6 \text{ N/mm}^2 = 1.6 \text{ MPa}$$

Since the induced shear stress in the flange is less than 8 MPa, therefore the design of flange is safe.

3. Design for bolts

Let d_1 = Nominal diameter of bolts.

Since the diameter of the shaft is 35 mm, therefore let us take the number of bolts, $n = 3$ and pitch circle diameter of bolts,

$$D_1 = 3d = 3 \times 35 = 105 \text{ mm}$$

The bolts are subjected to shear stress due to the torque transmitted. We know that the maximum torque transmitted (T_{\max}),

$$(d_1)^2 = 215 \times 10^3 / 4950 = 43.43 \text{ or } d_1 = 6.6 \text{ mm}$$

$$215 \times 10^3 = \frac{\pi}{4} (d_1)^2 \tau_b \times n \times \frac{D_1}{2} = \frac{\pi}{4} (d_1)^2 40 \times 3 \times \frac{105}{2} = 4950 (d_1)^2$$

Assuming coarse threads, the nearest standard size of bolt is M 8.

Ans. Other proportions of the flange are taken as follows:

Outer diameter of the flange,

$$D_2 = 4d = 4 \times 35 = 140 \text{ mm Ans.}$$

Thickness of the protective circumferential flange,

$$t_p = 0.25d = 0.25 \times 35 = 8.75 \text{ say } 10 \text{ mm Ans.}$$

Chapter-5

DESIGN OF CLOSED COIL HELICAL SPRING

Spring:

Spring is defined as an elastic machine element (flexible element) that deflects under the action of load and returns to its original shape when load is removed.

Important functions and applications of spring :

1. Springs are used to absorb shocks and vibrations eg: vehicle suspension springs, railway buffers to control energy, buffer springs in elevators and vibration mounts for machinery.
2. Measuring forces : Spring balances, gages
3. Storing of energy in clocks ,toys ,movie cameras, circuit breakers ,starters
4. Springs are used to apply force and control motion.

Commonly used spring materials :

One of the important considerations in spring design is the choice of the spring material. Some of the common spring materials are given below.

Hard-drawn wire: This is cold drawn, cheapest spring steel. Normally used for low stress and static load. The material is not suitable at subzero temperatures or at temperatures above 120°C .

Oil-tempered wire:

It is a cold drawn, quenched, tempered, and general purpose spring steel. However, it is not suitable for fatigue or sudden loads, at subzero temperatures and at temperatures above 180°C . When we go for highly stressed conditions then alloy steels are useful.

Chrome Vanadium:

This alloy spring steel is used for high stress conditions and at high temperature up to 220°C . It is good for fatigue resistance and long endurance for shock and impact loads.

Chrome Silicon:

This material can be used for highly stressed springs. It offers excellent service for long life, shock loading and for temperature up to 250°C .

Music wire:

This spring material is most widely used for small springs. It is the toughest and has highest tensile strength and can withstand repeated loading at high stresses. However, it can not be used at subzero temperatures or at temperatures above 120°C . Normally when we talk about springs we will find that the music wire is a common choice for springs.

Stainless steel:

Widely used alloy spring materials.

Phosphor Bronze / Spring Brass:

It has good corrosion resistance and electrical conductivity. That's the reason it is commonly used for contacts in electrical switches. Spring brass can be used at subzero temperatures.

Helical spring:

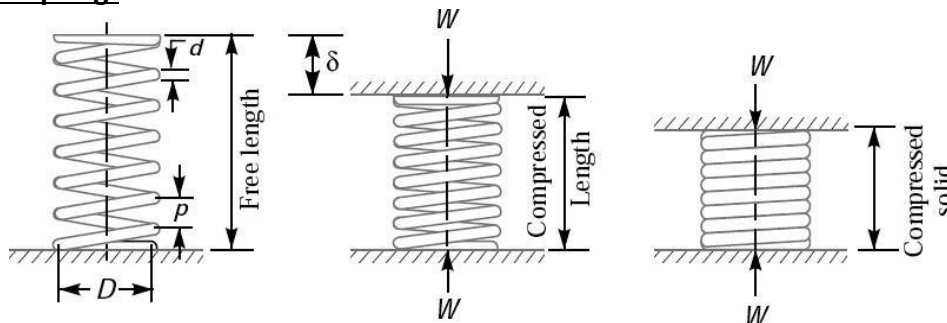

A closed coiled Helical spring is also known as tension or extension spring because the wire undergoes torsion. Here, the torsional stress is extremely high. It is caused by the twisting of the spring. It also mitigates any bending stress. If the helix is said to lie in a plane, then the turns of the spring are at right angles to the axis of the helix. This is possible because the springs are wound very tightly.

TERMS USED IN COMPRESSION SPRING:

SOLID LENGTH:

When the compression spring is compressed until the coils come in contact with each other, then the spring is said to be solid. The solid length of a spring is the product of total number of coils and the diameter of the wire.

Mathematically, Solid length of the spring,

$$L_S = n'.d$$

Where, n' = total number of coils

d = diameter of the wire

FREE LENGTH:

The free length of a compression spring, as shown in Fig., is the length of the spring in the free or unloaded condition. It is equal to the solid length plus the maximum deflection or compression of the spring and the clearance between the adjacent coils (when fully compressed).

Mathematically,

$$L_F = n'.d + \delta_{max} + 0.15 \delta_{max}$$

Spring index:

The spring index is defined as the ratio of the mean diameter of the coil to the diameter of the wire.

Mathematically,

$$\text{Spring index, } C = D / d$$

Where, D = Mean diameter of the coil, and d = Diameter of the wire.

Spring rate:

The spring rate (or stiffness or spring constant) is defined as the load required per unit deflection of the spring.

Mathematically,

$$\text{Spring rate, } k = W / \delta$$

Where, W = Load, and δ = Deflection of the spring.

PITCH :

The pitch of the coil is defined as the axial distance between adjacent coils in uncompressed state.

Mathematically,

$$\text{Pitch of the coil, } p = \frac{\text{Free length}}{n' - 1}$$

The pitch of the coil may also be obtained by using the following relation, i.e.

$$\text{Pitch of the coil, } p = \frac{L_F - L_S}{n'} + d$$

Where, L_F = Free length of the spring,

L_S = Solid length of the spring,

n' = Total number of coils, and

d = Diameter of the wire.

STRESSES IN HELICAL SPRING :

Consider a helical compression spring made of circular wire and subjected to an axial load W , as shown in Fig.

- Let D = Mean diameter of the spring coil,
 d = Diameter of the spring wire,
 n = Number of active coils,
 G = Modulus of rigidity for the spring material,
 W = Axial load on the spring,
 τ = Maximum shear stress induced in the wire,
 C = Spring index = D/d ,
 p = Pitch of the coils, and
 δ = Deflection of the spring, as a result of an axial load W .

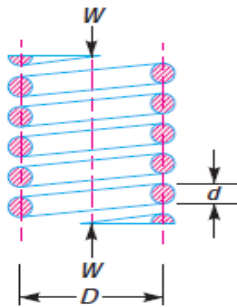

(a) Axially loaded helical spring.

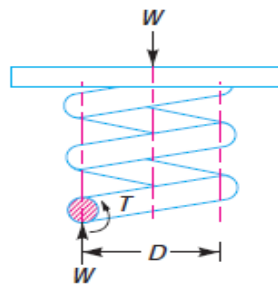

(b) Free body diagram showing that wire is subjected to torsional shear and a direct shear.

Now consider a part of the compression spring as shown in Fig (b).

The load W tends to rotate the wire due to the twisting moment (T) set up in the wire.

Thus torsional shear stress is induced in the wire. A little consideration will show that part of the spring, as shown in Fig (b), is in equilibrium under the action of two forces W and the twisting moment T .

We know that the twisting moment,

$$T = W \times \frac{D}{2} = \frac{\pi}{16} \times \tau_1 \times d^3$$

$$\tau_1 = \frac{8WD}{\pi d^3}$$

The torsional shear stress diagram is shown in Fig (a).

In addition to the torsional shear stress (τ_1) induced in the wire, the following stresses also act on the wire :

1. Direct shear stress due to the load W , and
2. Stress due to curvature of wire

We know that direct shear stress due to the load W ,

$$\tau_2 = \frac{\text{Load}}{\text{Cross-sectional area of the wire}}$$

$$= \frac{W}{\frac{\pi}{4} \times d^2} = \frac{4W}{\pi d^2}$$

The direct shear stress diagram is shown in Fig. (b) and the resultant diagram of torsional shear stress and direct shear stress is shown in Fig (c).

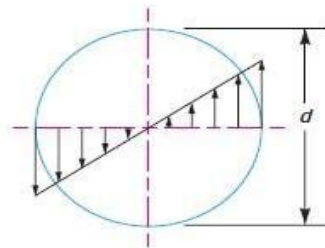

(a) Torsional shear stress diagram.

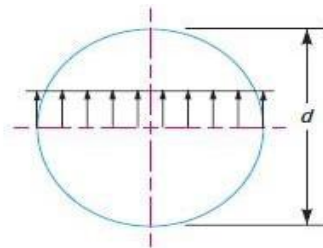

(b) Direct shear stress diagram.

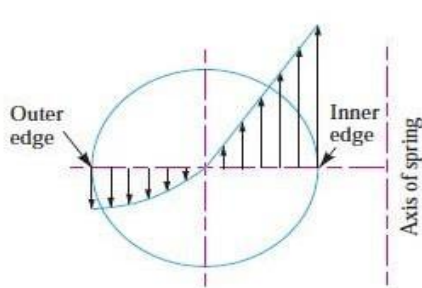

(c) Resultant torsional shear and direct shear stress diagram.

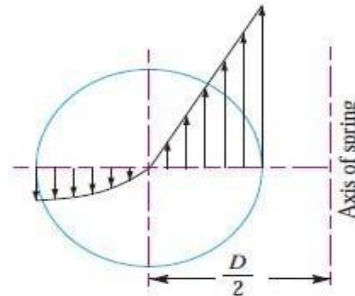

(d) Resultant torsional shear, direct shear and curvature shear stress diagram.

We know that the resultant shear stress induced in the wire,

$$\tau = \tau_1 \pm \tau_2 = \frac{8W.D}{\pi d^3} \pm \frac{4W}{\pi d^2}$$

The *positive* sign is used for the inner edge of the wire and *negative* sign is used for the outer edge of the wire. Since the stress is maximum at the inner edge of the wire, therefore

Maximum shear stress induced in the wire,

= Torsional shear stress + Direct shear stress

$$= \frac{8W.D}{\pi d^3} + \frac{4W}{\pi d^2} = \frac{8W.D}{\pi d^3} \left(1 + \frac{d}{2D} \right)$$

$$= \frac{8 W D}{\pi d^3} \left(1 + \frac{1}{2C} \right) = K_S \times \frac{8 W D}{\pi d^3} \quad \dots(iii)$$

... (Substituting $D/d = C$)

where $K_S = \text{Shear stress factor} = 1 + \frac{1}{2C}$

From the above equation, it can be observed that the effect of direct shear $\left(\frac{8 W D}{\pi d^3} \times \frac{1}{2C} \right)$ is appreciable for springs of small spring index C . Also we have neglected the effect of wire curvature in equation (iii). It may be noted that when the springs are subjected to static loads, the effect of wire curvature may be neglected, because yielding of the material will relieve the stresses.

In order to consider the effects of both direct shear as well as curvature of the wire, a Wahl's stress factor (K) introduced by A.M. Wahl may be used. The resultant diagram of torsional shear, direct shear and curvature shear stress is shown in Fig. 23.11 (d).

∴ Maximum shear stress induced in the wire,

$$\tau = K \times \frac{8 W D}{\pi d^3} = K \times \frac{8 W C}{\pi d^2} \quad \dots(iv)$$

where $K = \frac{4C - 1}{4C - 4} + \frac{0.615}{C}$

The values of K for a given spring index (C) may be obtained from the graph as shown in Fig.

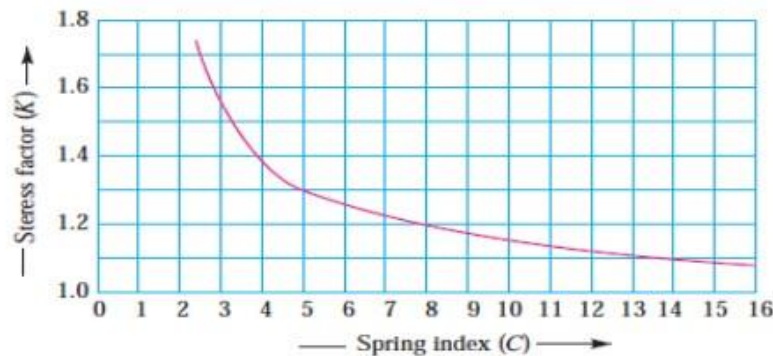

The Wahl's stress factor (K) may be considered as composed of two sub-factors, K_s and K_c , such that

$$K = K_s \times K_c$$

where $K_s = \text{Stress factor due to shear, and}$

$K_c = \text{Stress concentration factor due to curvature.}$

DEFLECTION OF HELICAL SPRING OF CIRCULAR WIRE:

The equation of torsion is $\frac{M_t}{J} = \frac{G\theta}{l}$.

θ = angle of twist in radians. For small angle, $\tan \theta = \theta = \frac{y}{R}$ and l = length of wire = $(\pi D) \cdot i$

Substituting, $\frac{(F \cdot R)}{\left(\frac{\pi d^4}{32}\right)} = \frac{G \cdot (y/R)}{i \pi D}$

$$\frac{F \cdot \frac{D}{2} \times 32}{\pi d^4} = \frac{G \cdot y}{i \pi D \cdot \frac{D}{2}}$$

$$\therefore \text{Deflection } y = \frac{F \cdot \frac{D}{2} \times 32 \times i \pi D \cdot \frac{D}{2}}{\pi d^4 G}$$

$$y = \frac{8FD^3i}{Gd^4} = \frac{8FC^3i}{Gd} \quad \left(\because C = \frac{D}{d} \right)$$

Knowing the deflection for a given load, one can easily estimate the no. of active turns requires using

$$i = \frac{yGd^4}{8FD^3} = \frac{yGd}{8FC^3}$$

$\delta = \theta \times (\text{length of bracket})$
 $= \theta \times (D/2)$

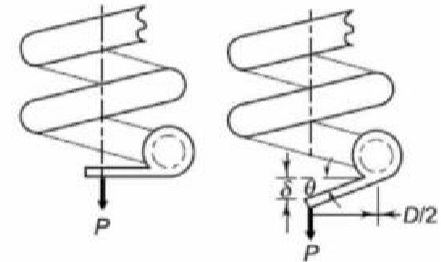

Deflection in helical spring

Deflection in a helical spring, δ

$$y = \frac{8FD^3i}{Gd^4}$$

Design parameter (spring rate or stiffness)

$$F_0 = \frac{F}{y} = \frac{Gd^4}{8D^3i}$$

- i : number of active coils
- F : Axial force
- D : Mean diameter of coil
- G : Modulus of rigidity
- d : diameter of spring wire
- F_0 : spring stiffness ,spring rate

SURGE IN SPRING:

When one end of a helical spring is resting on a rigid support and the other end is loaded suddenly, then all the coils of the spring will not suddenly deflect equally, because some time is required for the propagation of stress along the spring wire.

In the beginning, the end coils of the spring in contact with the applied load take up whole of the deflection and then it transmits a large part of its deflection to the adjacent coils.

In this way, a wave of compression propagates through the coils to the supported end from where it is reflected back to the deflected end.

This wave of compression travels along the spring indefinitely.

If the applied load is of fluctuating type as in the case of valve spring in internal combustion engines and if the time interval between the load applications is equal to the time required for the wave to travel from one end to the other end, then resonance will occur.

This results in very large deflections of the coils and correspondingly very high stresses.

Under these conditions, it is just possible that the spring may fail. This phenomenon is called **surge**.

NUMERICALS:

Q.1. Design a helical spring to support a tensile load of 6 kN and a stiffness of 100 N/mm. The spring index is 6. The spring is made of steel having allowable stress of 300 MPa. Take $G = 80$ GPa.

Solution:

$$F = 6000 \text{ N}, \quad F_o = 100 \text{ N/mm} = \frac{F}{y}$$

∴ Deflection

$$y = \frac{F}{F_o} = \frac{6000}{100} = 60 \text{ mm}$$

$$C = 6, \quad \tau = 300 \text{ MPa}, \quad G = 80 \times 10^3 \text{ MPa}$$

Step 1. Shear stress

$$\tau = \frac{8FCk}{\pi d^2}$$

$$k = \frac{4C-1}{4C-4} + \frac{0.615}{C} = \frac{4 \times 6 - 1}{4 \times 6 - 4} + \frac{0.615}{6} = 1.2525$$

$$300 = \frac{8 \times 6000 \times 6 \times 1.2525}{\pi d^2} \Rightarrow d = 19.56 \approx 20 \text{ mm}$$

Step 2. Mean coil dia

$$D = Cd = 6 \times 20 = 120 \text{ mm}$$

Inside dia of coil

$$D_i = D - d = 120 - 20 = 100 \text{ mm}$$

Outside dia of coil

$$D_o = D + d = 120 + 20 = 140 \text{ mm}$$

Step 3. Deflection

$$y = \frac{8FD^3i}{Gd^4} = \frac{8 \times 6000 \times 120^3 \times i}{80 \times 10^3 \times 20^4} = 60$$

∴ No. of active coils

$$i = 9.26 \approx 10 \text{ coils}$$

Step 4. Free length

$$l_o = (id) + 2D$$

(assuming no clearance between coils)

$$l_o = 10 \times 20 + 2 \times 120 = 440 \text{ mm}$$

Step 5. Pitch

$$p = d = 20 \text{ mm}$$

Step 6. Stiffness

$$F_o = \frac{F}{y} = 100 \text{ N/mm}$$

Step 7. Length of wire

$$= \pi D^2 = \pi D(i+2)$$

$$l_w = \pi \times 120 (10 + 2) = 4523.9 \text{ mm}$$

Q.2. A helical spring of wire diameter 6mm and spring index 6 is acted by an initial load of 800N. After compressing it further by 10mm the stress in the wire is 500MPa. Find the number of active coils. $G = 84000\text{MPa}$.

Solution:

$$D = \text{Spring index } (C) \times d = 36\text{mm}$$

$$\tau_{\max} = (K_w) \times (8FD / \pi d^3)$$

$$K_w = (4C-1 / 4C-4) + (0.615 / C) = 1.2525$$

Or

$$500 = 1.2525 \times (8F \times 36 / \pi \times F)$$

$$\text{Therefore } F = 940.86 \text{ N}$$

$$K = F / \delta$$

$$= (940.6 - 800) / 10$$

$$= 14 \text{ N/mm}$$

$$K = (Gd^4) / (8D^4N)$$

Or

$$N = (Gd^4) / (K8D^3N)$$

$$= (84000 \times 6^4) / 14 \times 8 \times 36^3$$

$$= 21 \text{ turns.}$$

A close coiled helical spring is made of 5 mm diameter wire. It is made up of 30 coils, each of mean diameter 75 mm. If the maximum stress in the spring is not to exceed 200 MPa, then determine (a) the proof load (b) the extension of the spring when carrying this load. Take $G = 80 \text{ GPa}$.

Solution:

Here, we have $d = 5 \text{ mm}$

$$n = 30$$

$$D = 75\text{mm}, R = 37.5 \text{ mm}$$

$$(f_s)_{\max} = 200 \text{ MPa}$$

$$G = 80 \text{ GPa}$$

$$\therefore W = \frac{\pi d^3}{8D} f_s$$

$$\text{Thus, proof load} = \frac{\pi(5)^3}{8 \times 75} \times 200 = 131 \text{ N}$$

$$\text{Deflection} \quad \delta = \frac{64 WR^3 n}{Gd^4}$$

$$\delta = \frac{64 \times 131 \times (37.5)^3 \times 30}{(80 \times 10^3) (5)^4} = 265.5 \text{ mm}$$

A helical spring in which the slope of the helix may be assumed small, is required to transmit a maximum pull of 1 kN and to extend 10 mm for 200 N load. If the mean diameter of the coil is to be the 80 mm, find the suitable diameter for the wire and number of coils required. Take $G = 80$ GPa and allowable shear stress as 100 MPa.

Solution

Shear stress, $f_s = \frac{8WD}{\pi d^3}$

$$\therefore d^3 = \frac{8WD}{\pi f_s} = \frac{8 \times 1000 \times 80}{\pi \times 100}$$

Here, we have $W = 1000$ N $D = 80$ mm

$f_s = 100$ MPa

\therefore Diameter of spring wire = 12.68 mm.

Now $\delta = 10$ mm for $W = 200$ N.

$$\begin{aligned} \therefore \text{Spring constant, } k &= \frac{W}{\delta} = \frac{200}{10} = 20 \text{ N/mm} \\ &= \frac{20}{10^{-3}} = 2 \times 10^4 \text{ N/m} \end{aligned}$$

We have, $C = 80$ GPa

$$\delta = \frac{8WD^3n}{Gd^4}$$

$$\begin{aligned} \therefore n &= \frac{Gd^4}{8 \left(\frac{W}{\delta} \right) D^3} = \frac{(80 \times 10^3) (12.68)^4}{8 \times 20 \times (80)^3} \\ &= 25.28 \end{aligned}$$

Number of coils required = 25.28 say 26.